

JAVNI INFRASTRUKTURNI SUSTAVI

PROMET U MIROVANJU

SVEUČILIŠTE
JOSIPA JURJA STROSSMAYERA
U OSIJEKU



JOSIP JURAJ STROSSMAYER
UNIVERSITY OF OSIJEK

SADRŽAJ

- PODJELA PARKIRALIŠTA
- PROJEKTNI ELEMENTI
 - MJERODAVNO VOZILO
 - HORIZONTALNI ZAVOJI
 - DIMENZIJE MODULA
 - TIPSKA RJEŠENJA
- GARAŽNO PARKIRNE GRAĐEVINE
 - OSNOVNI PROJEKTNI ELEMENTI
 - TIPSKA RJEŠENJA
 - MEHANIZIRANE GARAŽE
- PARKIRALIŠTA ZA DRUGE VRSTE VOZILA



PROMET U MIROVANJU

FUNKCIONALNA PODJELA PARKIRALIŠTA:

- parkirališta uz mjesto stanovanja
- parkirališta uz radna mjesta
- javna parkirališta (opće uporabe)



PODJELA PARKIRALIŠTA PREMA NAMIJENI:

- parkirališta za osobna vozila
- parkirališta za druge vrste vozila

PROMET U MIROVANJU

PODJELA PARKIRALIŠTA PREMA MJESTU PARKIRANJA:

- parkirališta u zatvorenim objektima
 - privatne garaže
 - garaže u stambenim objektima
 - garaže u javnim objektima (trgovački, sportski, kulturni centri)
 - javne garaže kao nezavisni objekti
- parkirališta na otvorenom
 - parkiranje na prometnicama
 - parkiranje na posebnim parkiralištima

PROMET U MIROVANJU

PODJELA PARKIRALIŠTA PREMA VREMENU KORIŠTENJA:

- parkirališta namijenjena dugotrajnom parkiranju
- parkirališta namijenjena kratkotrajnom parkiranju sa ili bez ograničenog vremena korištenja
- mjesta namijenjena zaustavljanju vozila – do 5 minuta ili do 15 minuta

PODJELA PARKIRALIŠTA PREMA NAPLATI

- parkirališta koja se ne naplaćuju
- parkirališta pod naplatom sa fiksnom tarifom (prema zonama)
- parkirališta pod naplatom sa progresivnom tarifom

PROMET U MIROVANJU

PARKIRALIŠTA UZ MJESTO STANOVANJA sastavni su dio opreme stana. Namijenjena su dugotrajnom parkiranju i mogu se realizirati kroz privatne garaže, i parkirališta u stambenim zgradama. Parkirališta na otvorenom mogu biti na prostoru uz stambene zgrade, na pristupnim ulicama i posebnim parkiralištima.



PROMET U MIROVANJU

PARKIRALIŠTA UZ MJESTO STANOVANJA



PROMET U MIROVANJU

PARKIRALIŠTA UZ RADNA MJESTA planiraju se uz značajnu koncentraciju radnih mjesta. I ova vrsta parkirališta pripada dugotrajnom parkiranju, ali mogu biti projektirana sa skromnijim projektnim elementima. Najčešće se organiziraju u prizemljima i podrumima poslovnih objekata ili na posebnim parkiralištima na otvorenom. Često su ograničenih kapaciteta.

Cilj je motivirati zaposlenike da koriste pogodnosti javnog prijevoza putnika za dolazak na posao.



PROMET U MIROVANJU

JAVNA PARKIRALIŠTA planiraju se uz atraktivne urbanističke sadržaje kao javni objekti. Mogu biti organizirana kao parkirališta u objektima javne namjene, na posebnom parkiralištu ili višeetažnim garažama kao nezavisnim objektima.



PROMET U MIROVANJU

PROJEKTNI STANDARDI

Polazeći od osnovnih funkcionalnih karakteristika projektiranje parkirališta bazira se na usklađivanju standardnih parkirnih modula i pristupnih prometnica sa prostornim mogućnostima konkretne lokacije.

PROJEKTNI CILJ

Postići efikasno obavljanje funkcije parkiranja uz racionalno (minimalno) trošenje prostornih resursa.



OBLIKOVNI ELEMENTI

PROMET U MIROVANJU

ELEMENTI PROJEKTIRANJA

MJERODAVNO VOZILO I PROSTORNI ZAHTJEVI

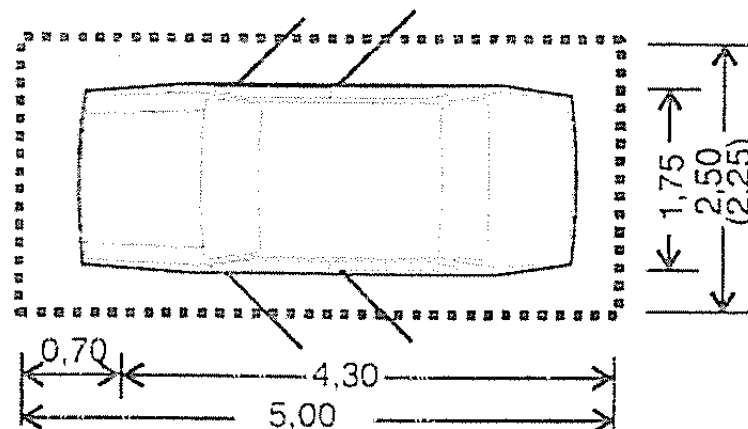
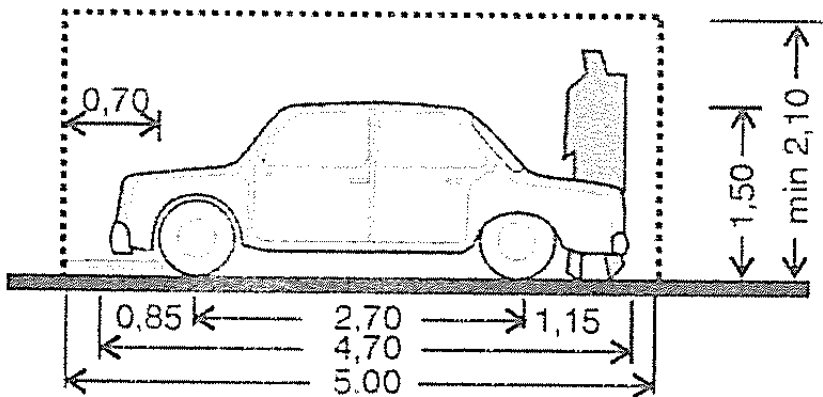

PROMET U MIROVANJU

ELEMENTI PROJEKTIRANJA

POTREBA PROŠIRENJA ZA MJERODAVNO OSOBNO VOZILO

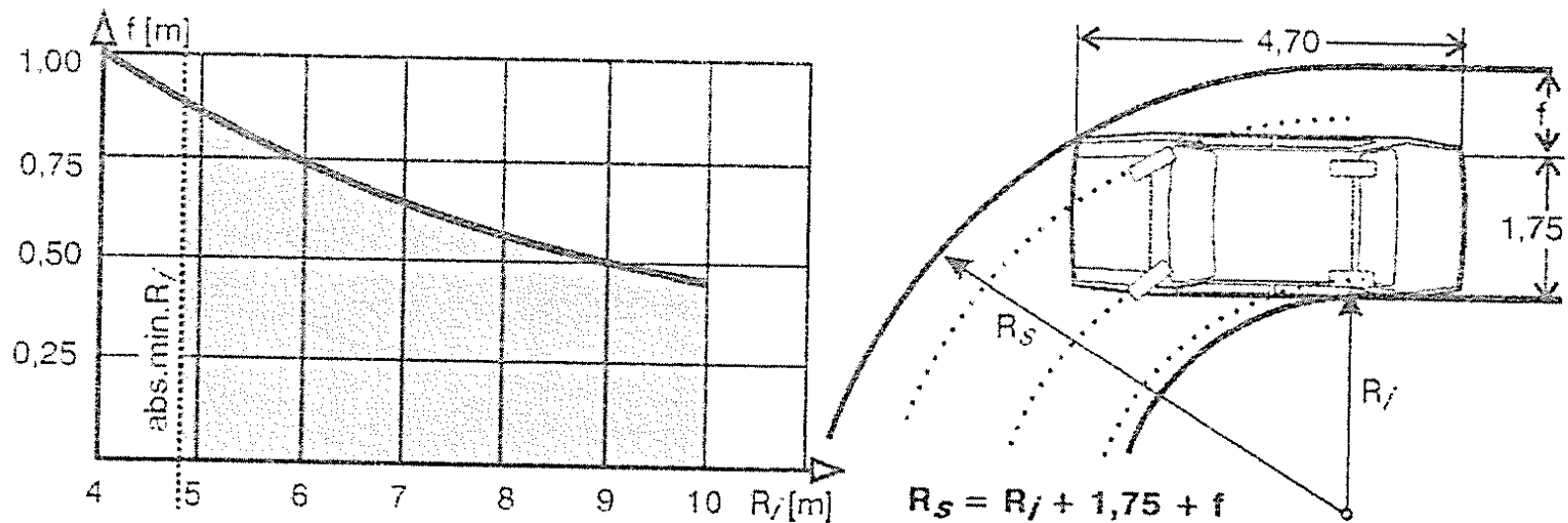

PROMET U MIROVANJU

ELEMENTI PROJEKTIRANJA

ŠIRINA PARKIRNOG MJESTA – KUT PARKIRANJA – ŠIRINA PRISTUPA

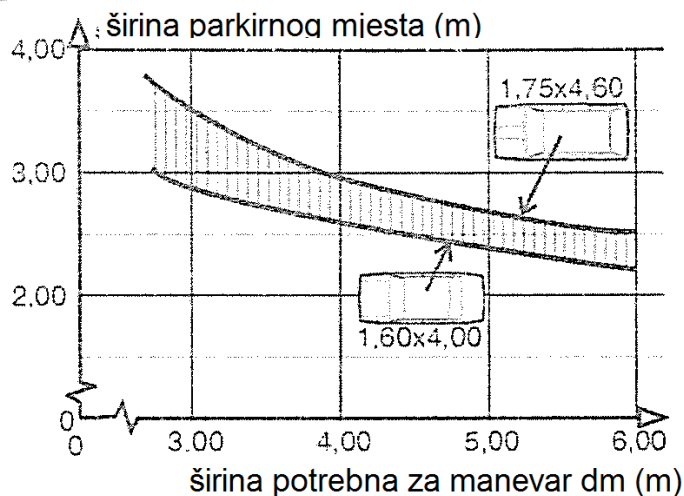
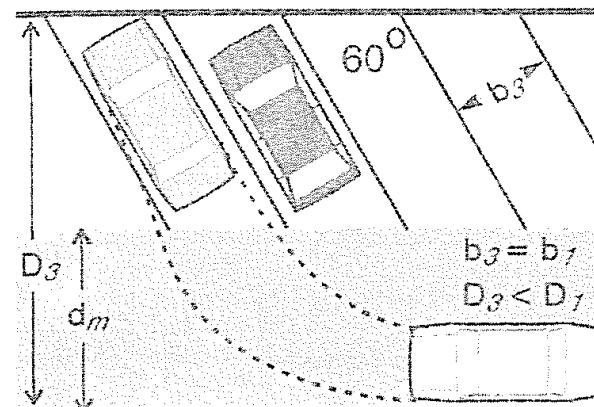
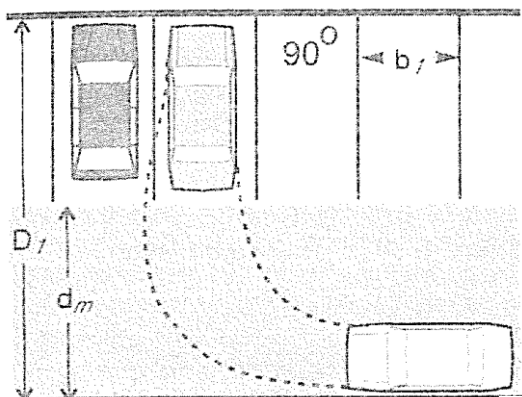

PROMET U MIROVANJU

ELEMENTI PROJEKTIRANJA

PARKIRNI MODULI ZA PARKIRANJE U PROFILU PROMETNICE

U nedostatku prostora koristi se rub pješačke staze

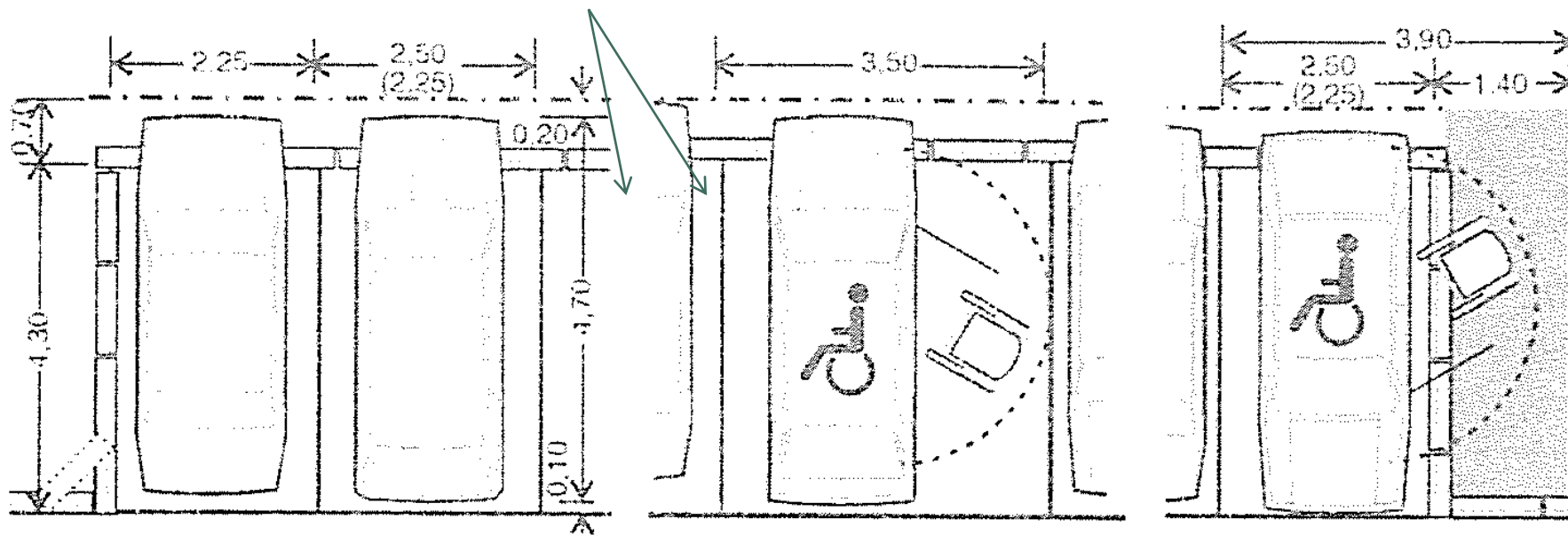

PARKIRNI MODUL ZA
OSOBNA VOZILA

PARKIRNI MODUL ZA
VOZILA ZA INVALIDE

PROMET U MIROVANJU

ELEMENTI PROJEKTIRANJA

PARKIRANJE U PROFILU PROMETNICE

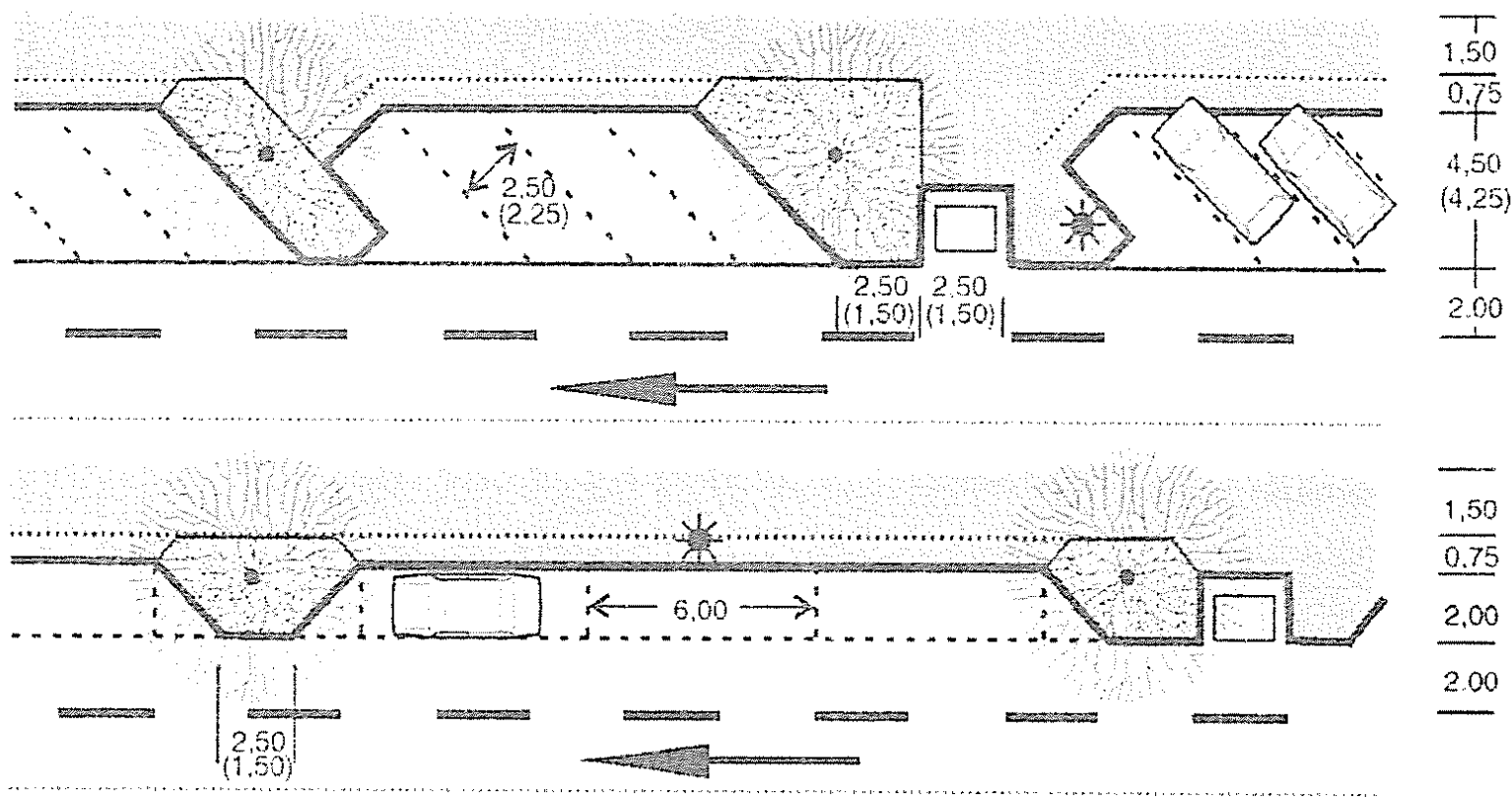

PROMET U MIROVANJU

ELEMENTI PROJEKTIRANJA

PARKIRANJE U PROFILU PRISTUPNE PROMETNICE

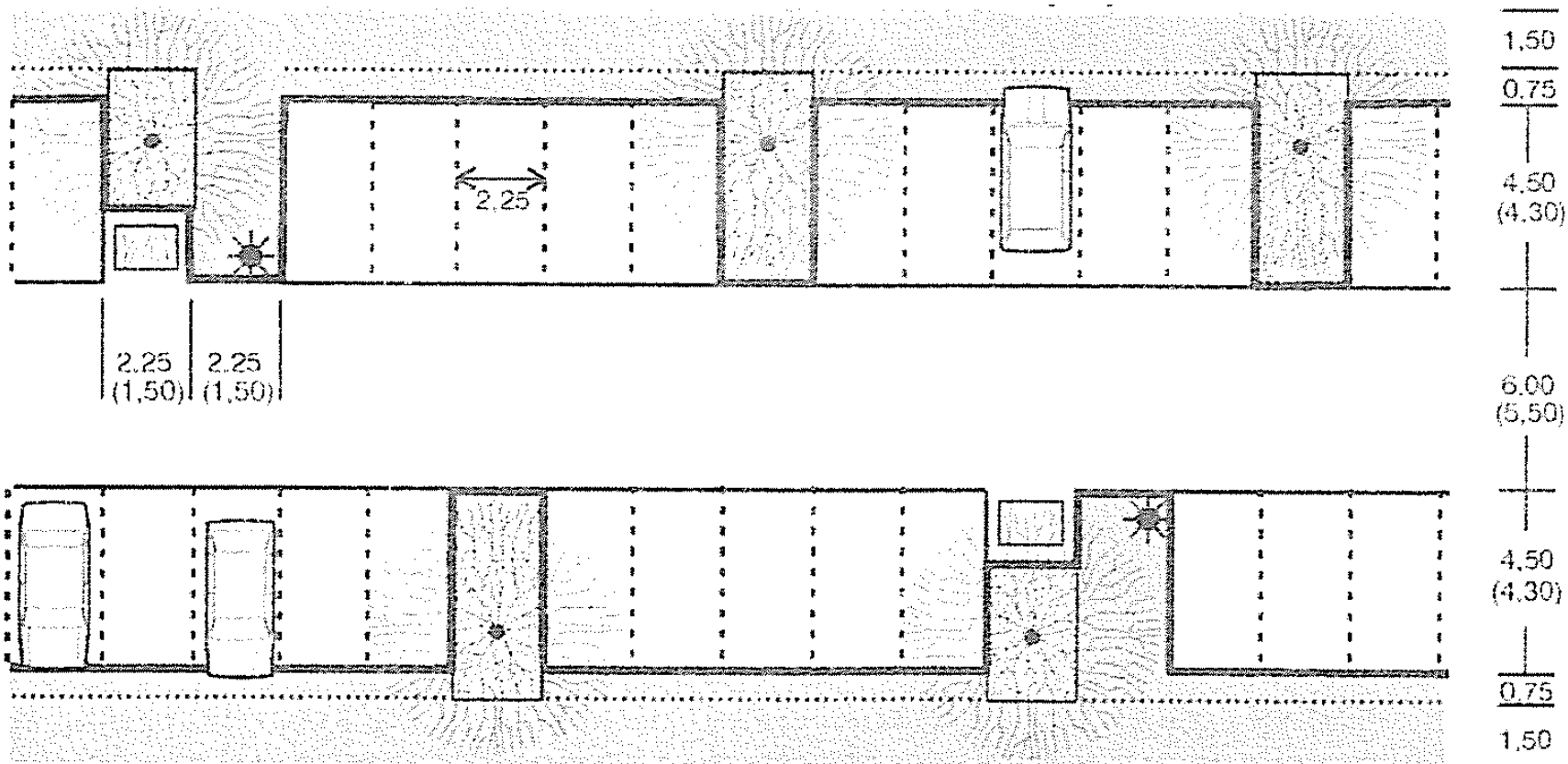

PROMET U MIROVANJU

PARKIRANJE U PROFILU PRISTUPNE PROMETNICE



PROMET U MIROVANJU

PARKIRANJE U PROFILU PRISTUPNE PROMETNICE

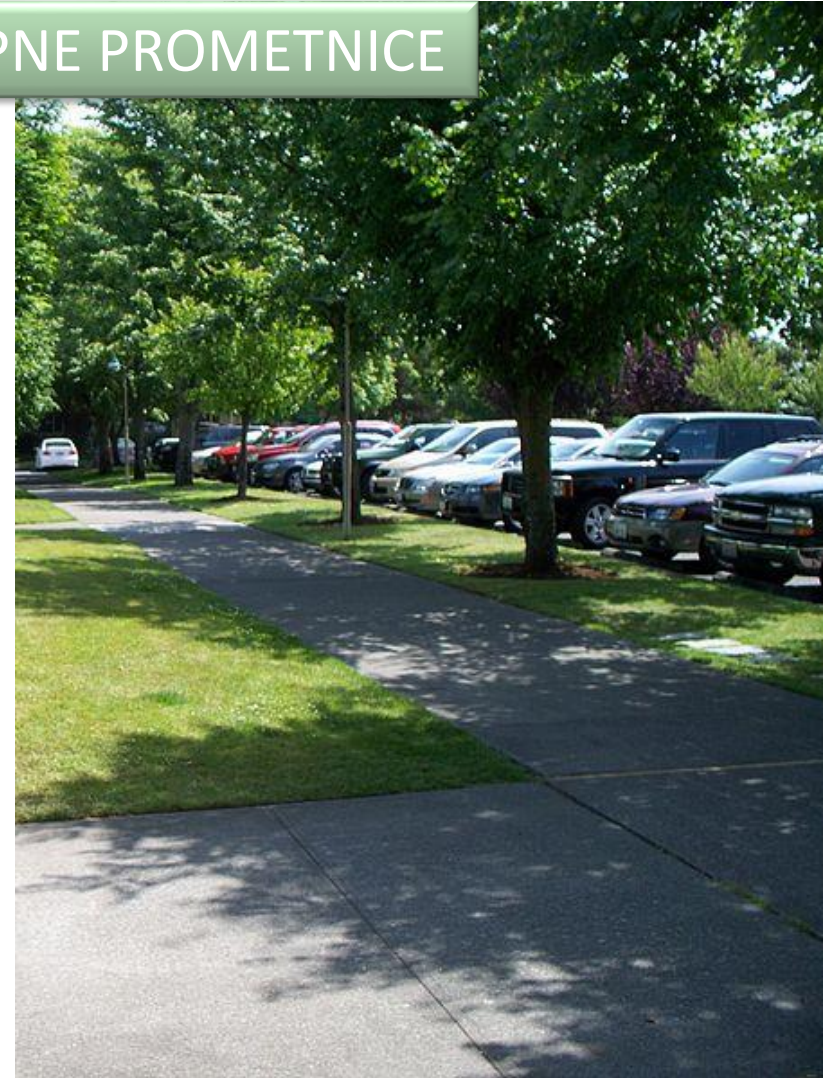

PROMET U MIROVANJU

ELEMENTI PROJEKTIRANJA

PARKIRANJE U PROFILU PRISTUPNE PROMETNICE SA INTEGRIRANIM PROMETOM

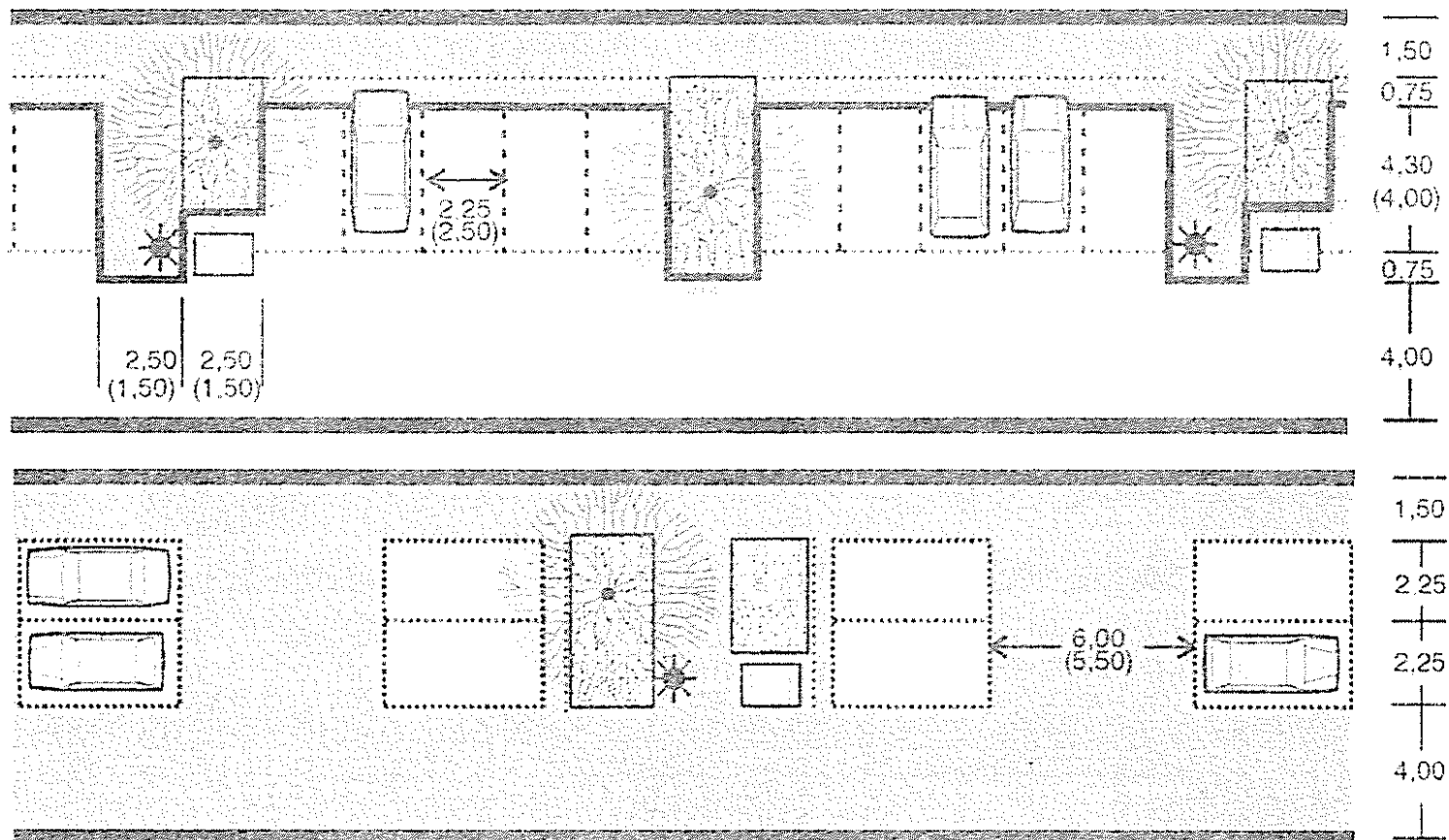

PROMET U MIROVANJU

ELEMENTI PROJEKTIRANJA POSEBNIH PARKIRALIŠTA

Tip A

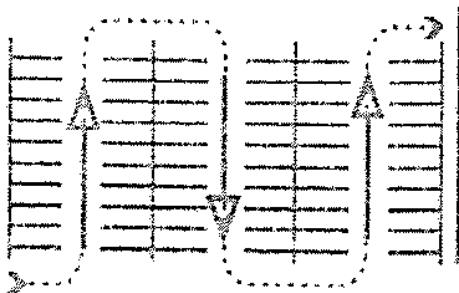

Shema organizacije smjera kretanja vozila na pristupima parkirnim mjestima.

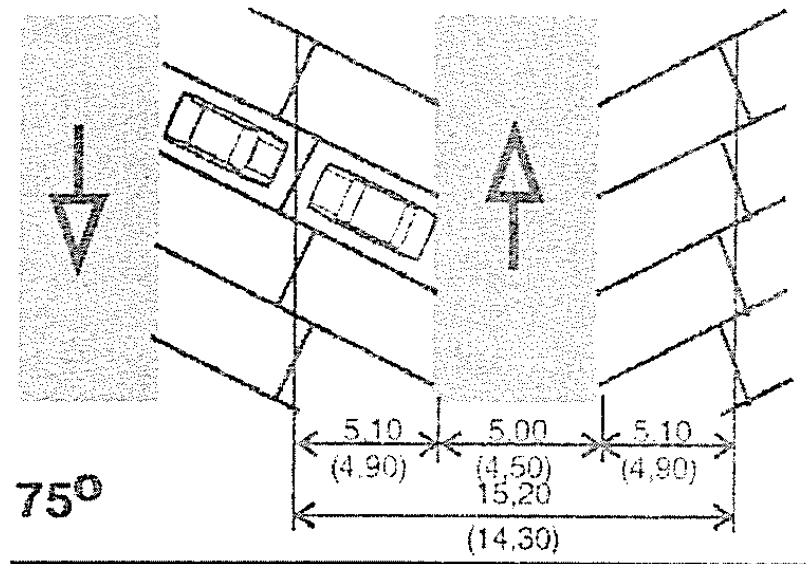
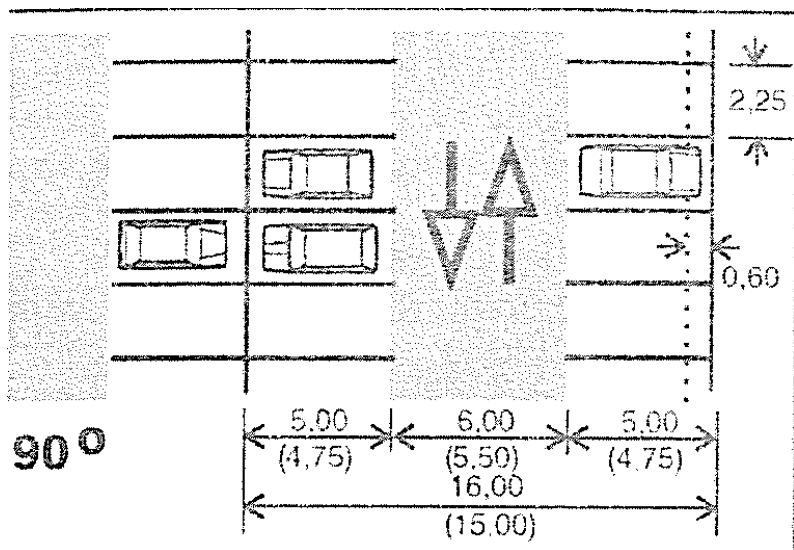

PROMET U MIROVANJU

ELEMENTI PROJEKTIRANJA POSEBNIH PARKIRALIŠTA

Tip A

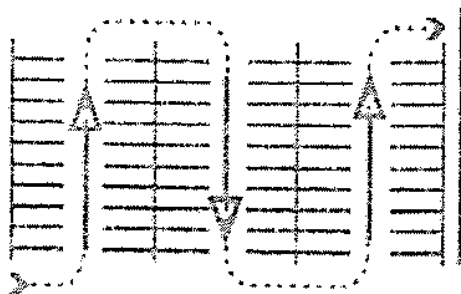

Shema organizacije smjera kretanja vozila na pristupima parkirnim mjestima.

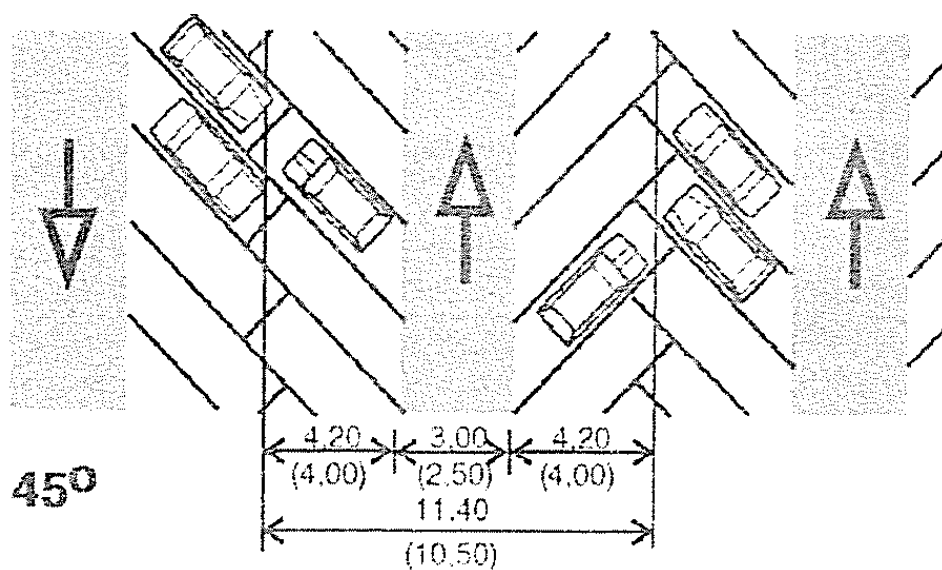
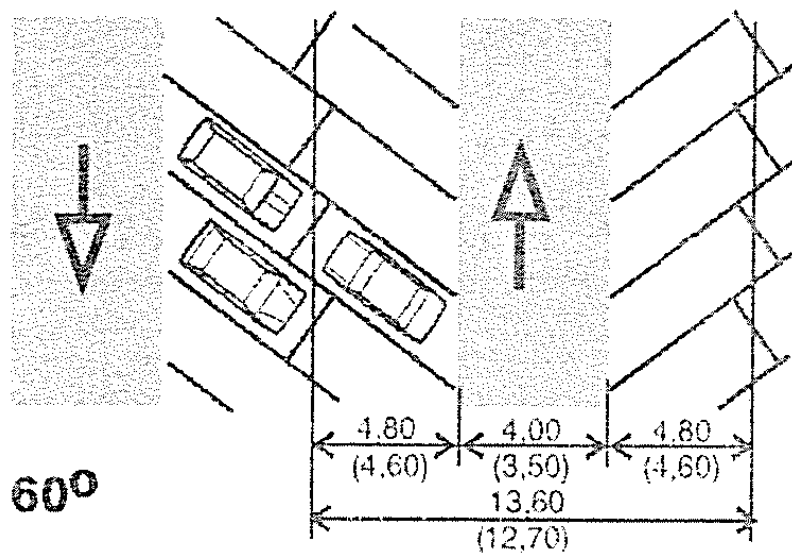

PROMET U MIROVANJU

ELEMENTI PROJEKTIRANJA POSEBNIH PARKIRALIŠTA

Tip B

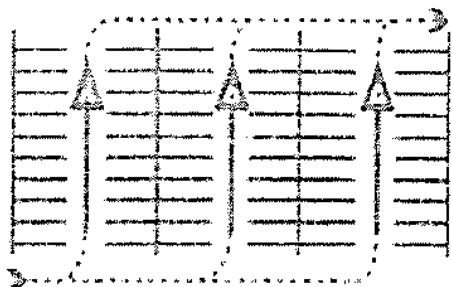

Shema organizacije smjera kretanja vozila na pristupima parkirnim mjestima.

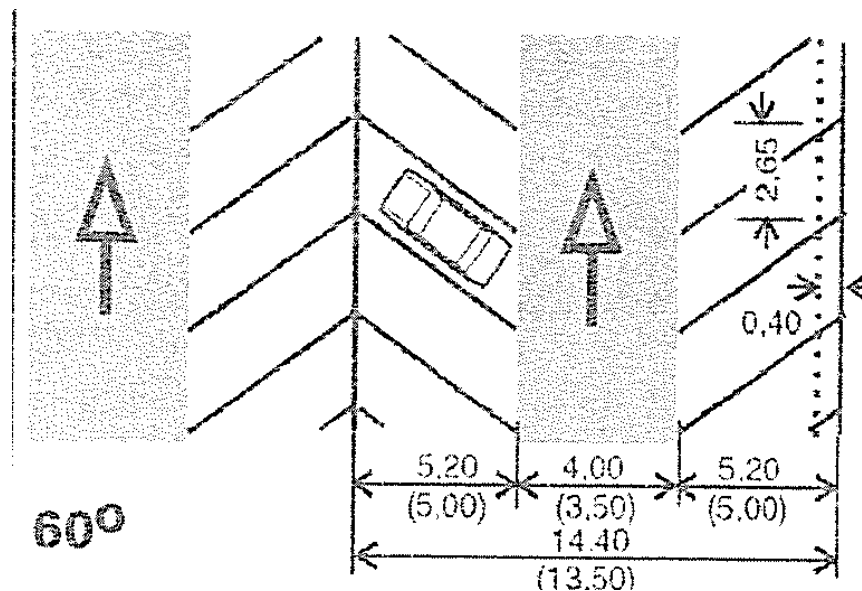
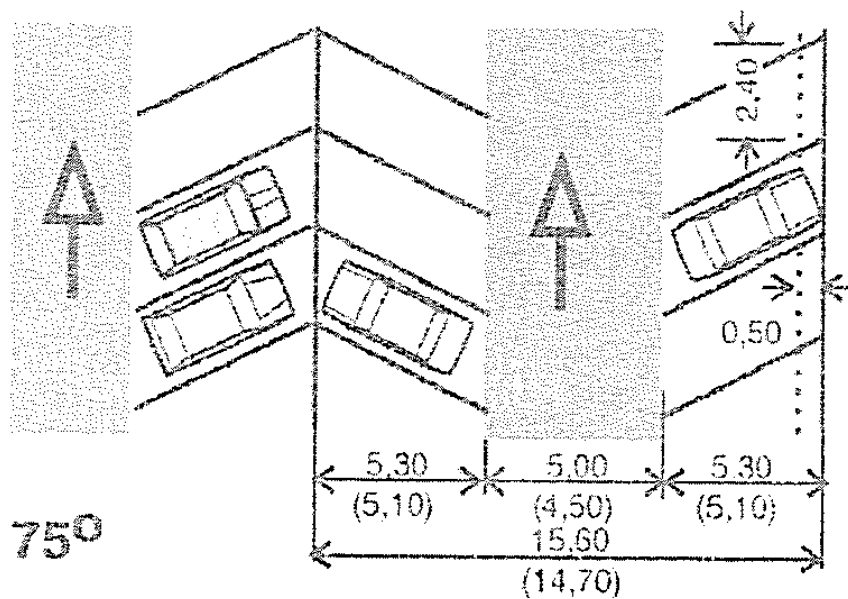

PROMET U MIROVANJU

ELEMENTI PROJEKTIRANJA POSEBNIH PARKIRALIŠTA

Tip B

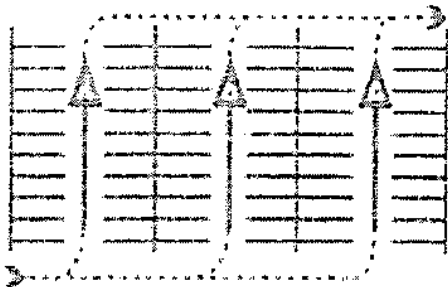

Shema organizacije smjera kretanja vozila na pristupima parkirnim mjestima.

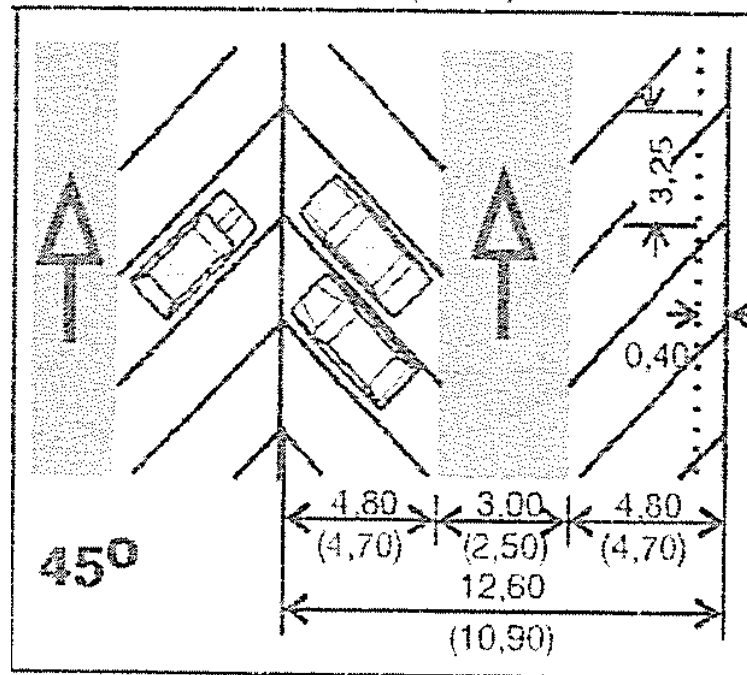

PROMET U MIROVANJU

POSEBNA PARKIRALIŠTA



PROMET U MIROVANJU

POSEBNA PARKIRALIŠTA



PROMET U MIROVANJU

POSEBNA PARKIRALIŠTA



PROMET U MIROVANJU

POSEBNA PARKIRALIŠTA U ZONAMA PROSTORNIH OGRANIČENJA



PROMET U MIROVANJU

POSEBNA PARKIRALIŠTA U ZONAMA PROSTORNIH OGRANIČENJA



PROMET U MIROVANJU

ELEMENTI PROJEKTIRANJA POSEBNIH PARKIRALIŠTA

PRIMJERI JAVNIH PARKIRALIŠTA SA NAPLATOM

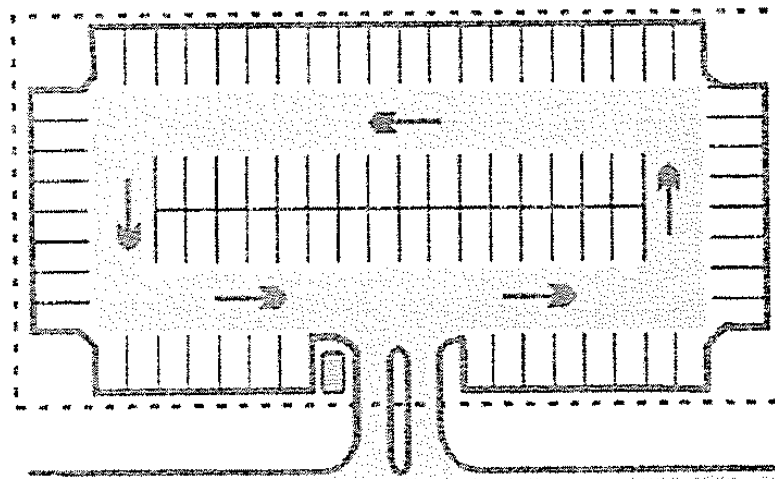
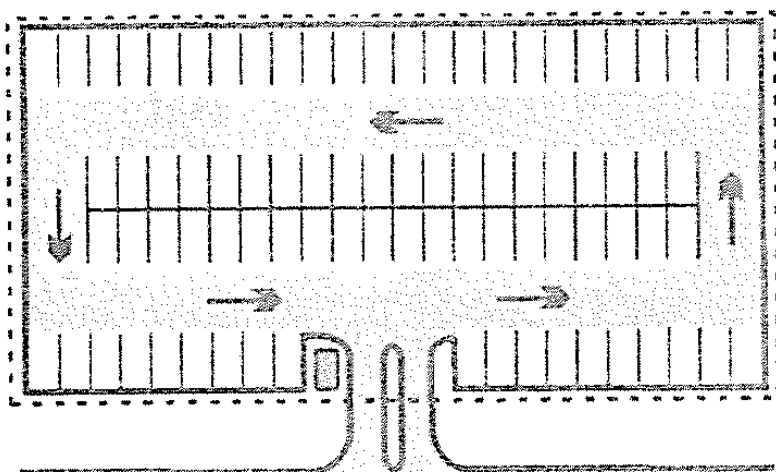

PROMET U MIROVANJU

ELEMENTI PROJEKTIRANJA POSEBNIH PARKIRALIŠTA

PRIMJERI JAVNIH PARKIRALIŠTA SA NAPLATOM

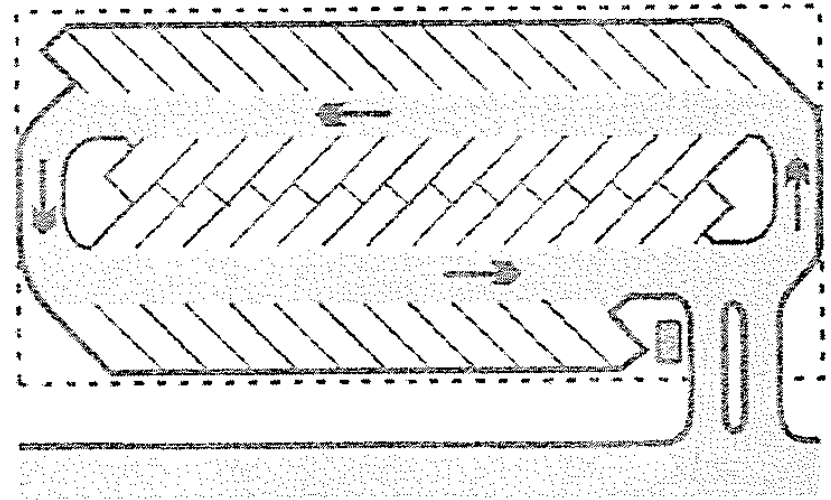
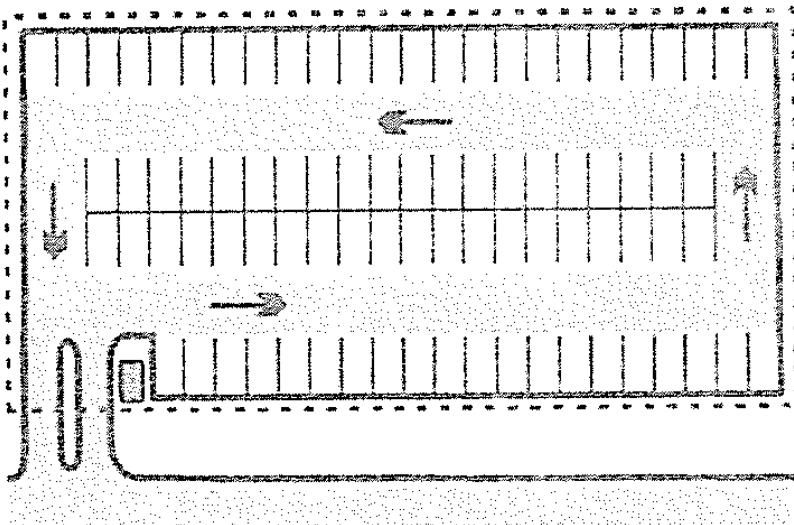

PROMET U MIROVANJU

ELEMENTI PROJEKTIRANJA POSEBNIH PARKIRALIŠTA

TIPSKA RJEŠENJA ULAZA/IZLAZA

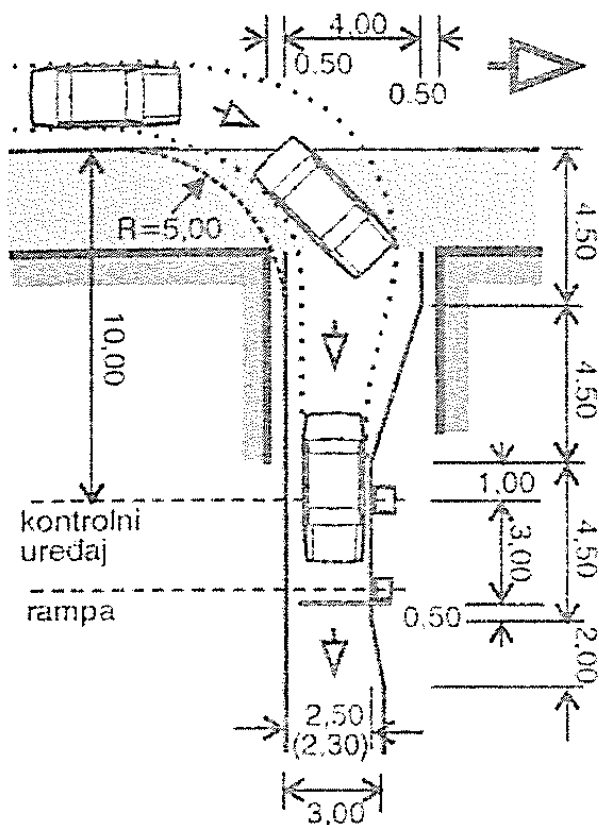

PARKIRALIŠTA ZA POSEBNE NAMJENE
MANJEG KAPACITETA

PROMET U MIROVANJU

ELEMENTI PROJEKTIRANJA POSEBNIH PARKIRALIŠTA

TIPSKA RJEŠENJA ULAZA/IZLAZA

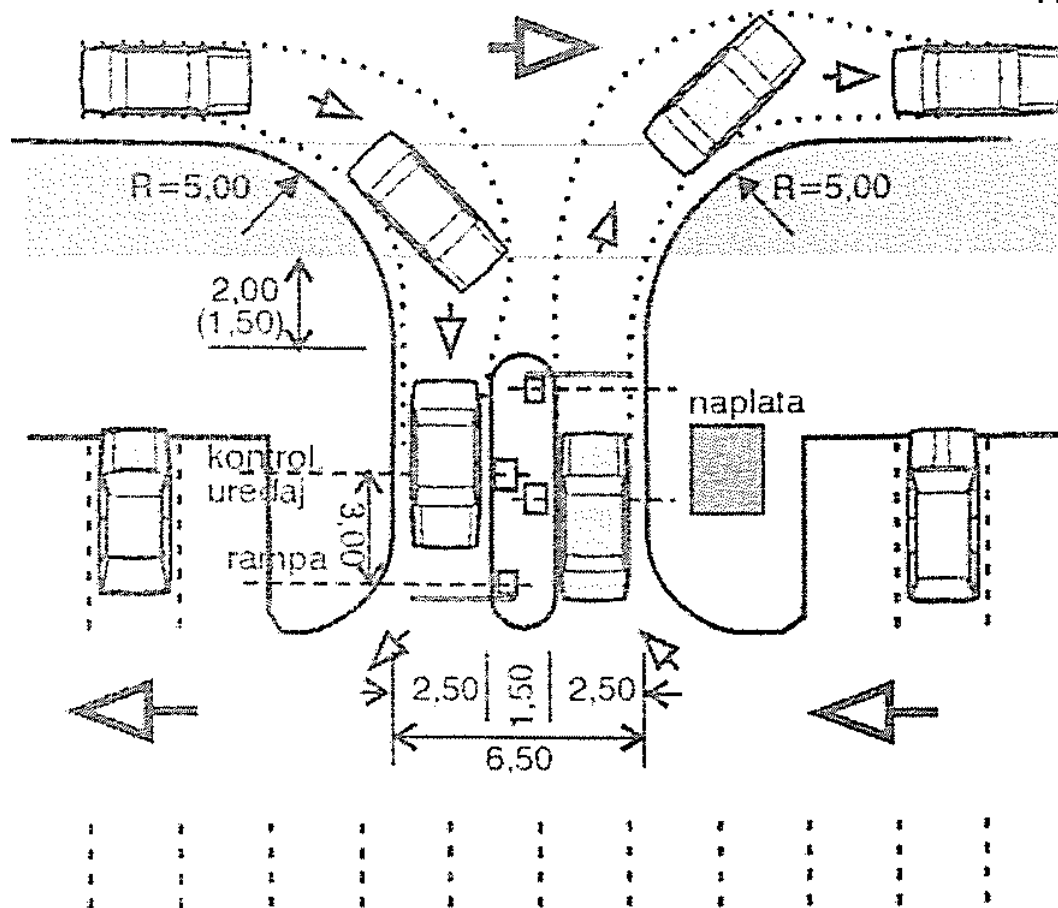

JAVNA PARKIRALIŠTA SA
NAPLATOM

PROMET U MIROVANJU

NAPLATA PARKIRANJA



PROMET U MIROVANJU

NAPLATA PARKIRANJA



Elektronički parkirni sustav, Yishun, Singapore

PROMET U MIROVANJU

GARAŽNO – PARKIRNE GRAĐEVINE

Višeetažne garažne i parkirne zgrade koriste se kao poseban način rješavanja problema parkiranja kada se iscrpe mogućnosti parkiranja na parkiralištima u jednoj razini.

Građevine mogu biti podzemne, nadzemne ili kombinirane, mogu biti javne (sa ili bez naplate) ili posebne namjene.

Prema broju parkirnih mjesta mogu biti manje građevine (do 300 parkirnih mjesta), srednje (do 800 mjesta) i velike građevine (do 1500 mjesta).

PROMET U MIROVANJU

GARAŽE



Parking Garages in Los Angeles

<https://www.laweekly.com/arts/five-most-beautiful-parking-garages-yes-parking-garages-in-los-angeles-2374094>

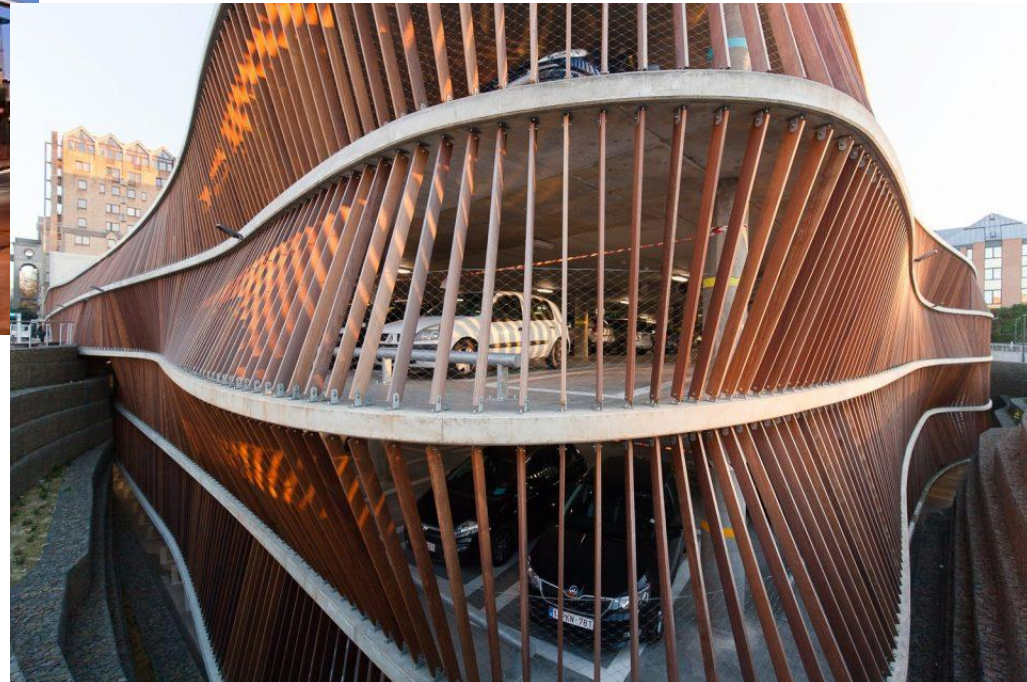

Parking garage for the Cliniques
Universitaires Saint-Luc hospital in Brussels

<https://weburbanist.com/2017/03/22/worlds-sexiest-parking-garage-has-a-new-competitor-for-the-crown/>

PROMET U MIROVANJU

GARAŽE



Ballet Valet, Miami



Sydney

PROMET U MIROVANJU

GARAŽE



GARAŽNO – PARKIRNE GRAĐEVINE



PROMET U MIROVANJU

GARAŽE



Design for a car park/ Miami Beach



PROMET U MIROVANJU

GARAŽE

Garaže za parkiranje omogućavaju bolje iskorištenje prostora za parkiranje u odnosu na klasična parkirališta, ali je izgradnja takvih objekata značajno skuplja. Iz ekonomskih razloga u garažama za parkiranje potrebno je osigurati dobru svakodnevnu popunjenost, a ključni faktori koji na to utječu su lokacija garaže, vrsta ponude i cijena parkiranja.



Wyandotte Parking Garage, Kansas City

PROMET U MIROVANJU

GARAŽE

Povećanje kapaciteta postojećeg objekta primjenom pokretnih platformi.

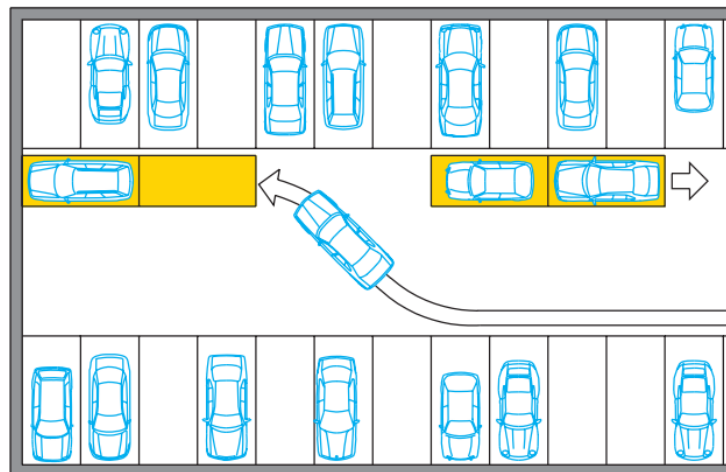
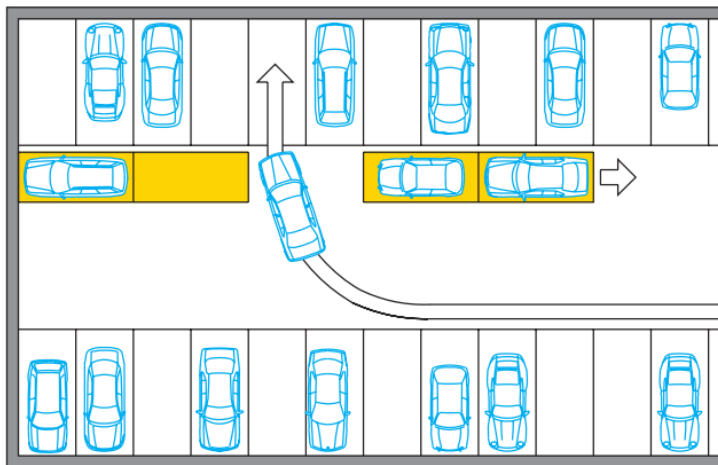

PROMET U MIROVANJU



GARAŽE

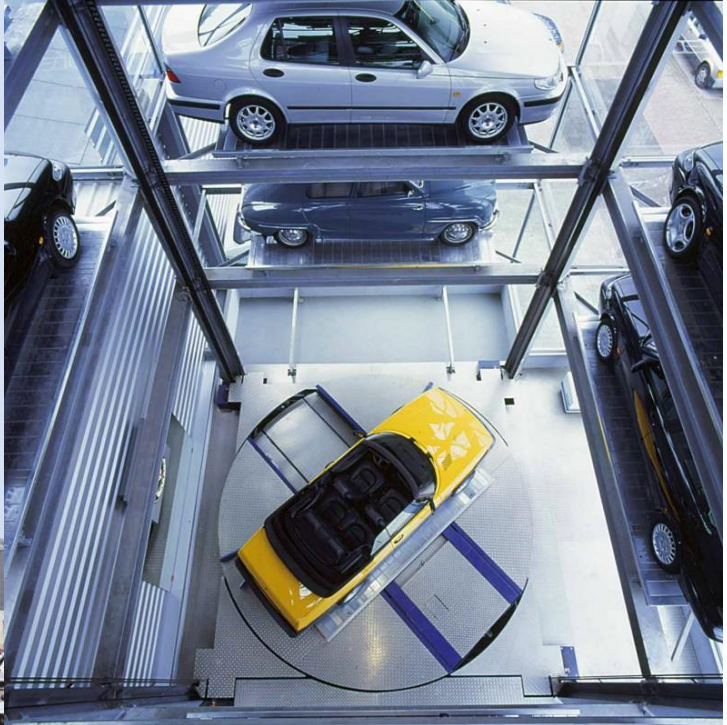

PROMET U MIROVANJU

ELEMENTI PROJEKTIRANJA GARAŽA

STANDARDNA PARKING ALINEJA

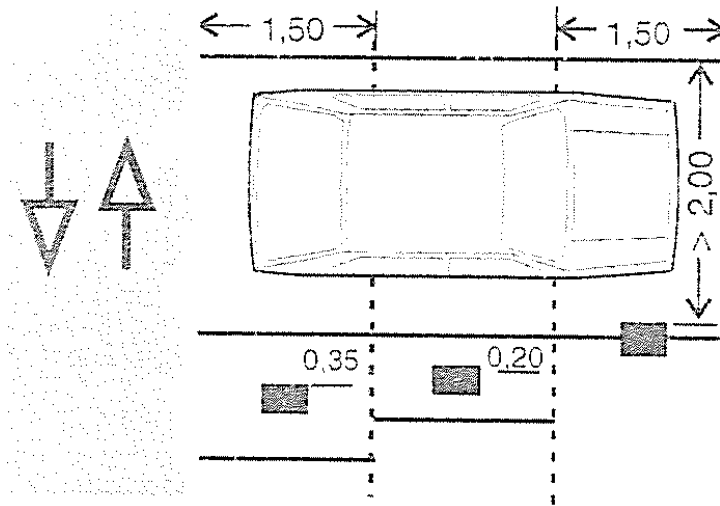
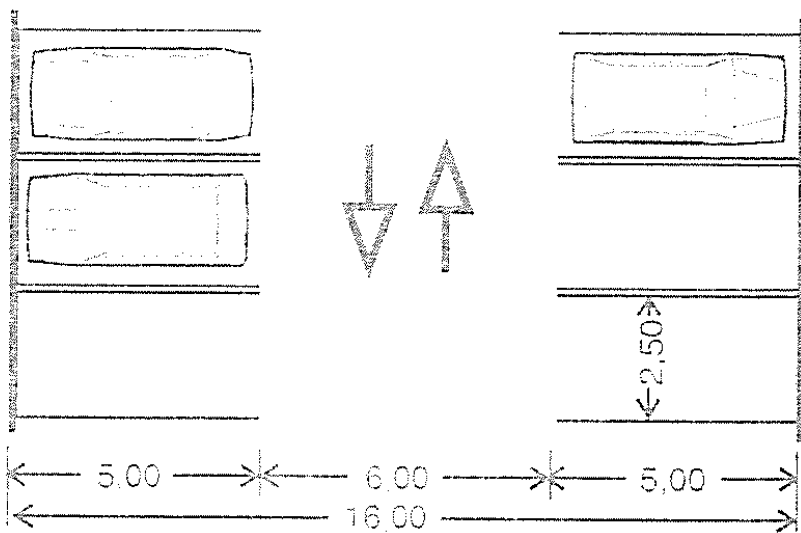

PROMET U MIROVANJU

STANDARDNA PARKIRNA ALINEJA



Parking Garage, Seattle

<https://news.theregistryps.com/urban-visions-acquires-parking-garage-near-seattles-waterfront-in-pioneer-square-for-13-1mm/>

PROMET U MIROVANJU

ELEMENTI PROJEKTIRANJA GARAŽA



PROMET U MIROVANJU

ELEMENTI PROJEKTIRANJA GARAŽA

STANDARDNA RJEŠENJA

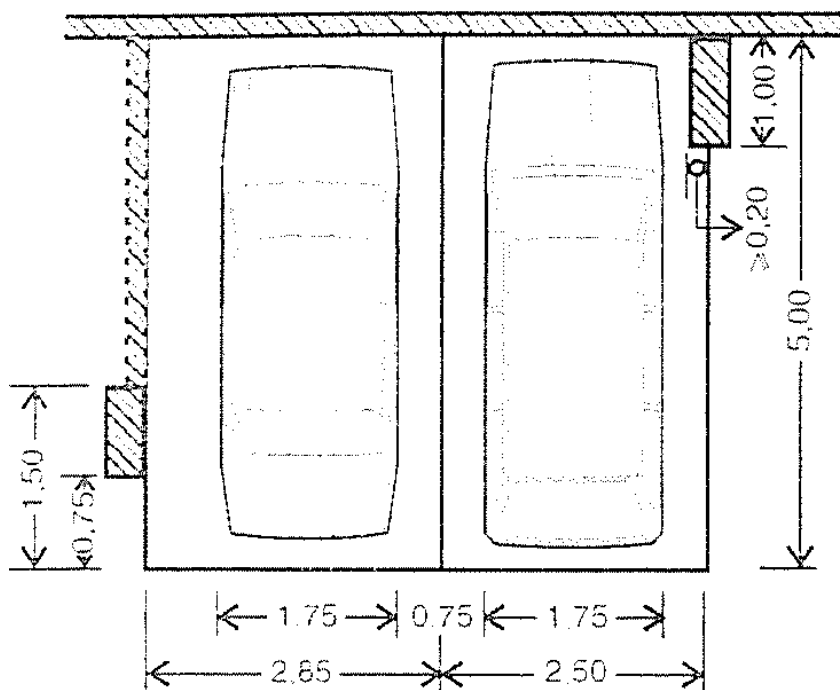

JAVNE GARAŽE

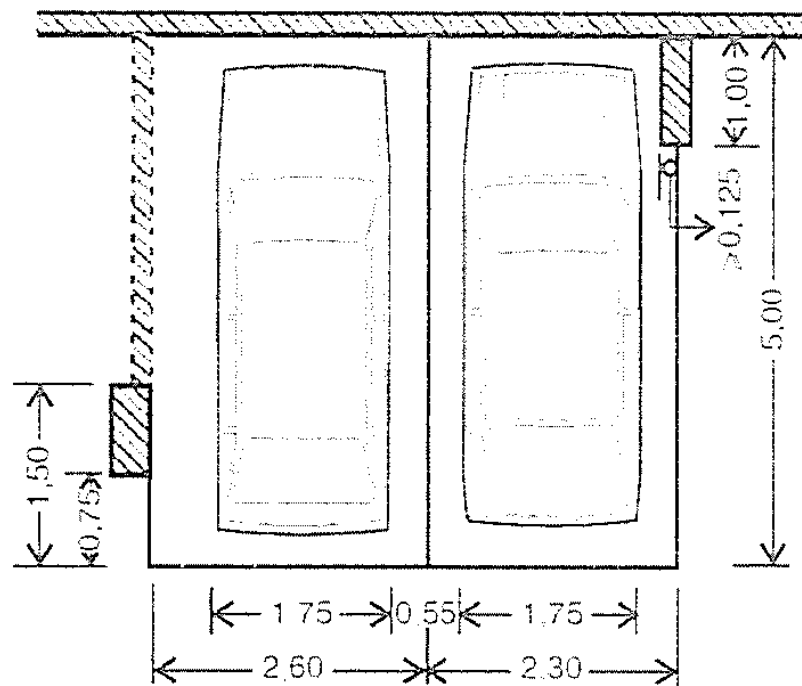

GARAŽE POSEBNE NAMJENE
I STAMBENE GARAŽE

PROMET U MIROVANJU

ELEMENTI PROJEKTIRANJA GARAŽA

TIPKE DISPOZICIJE

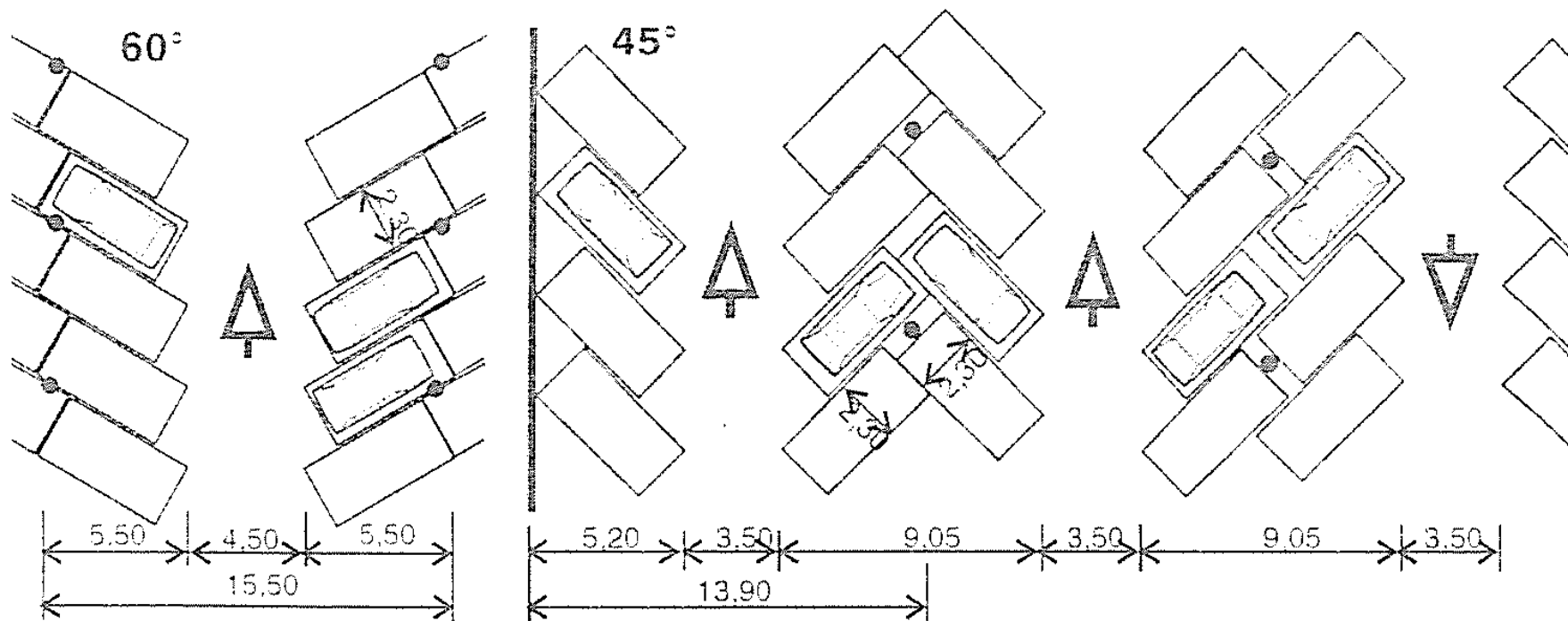

PROMET U MIROVANJU

ELEMENTI PROJEKTIRANJA GARAŽA

PRIMJERI PROSTORNIH RJEŠENJA

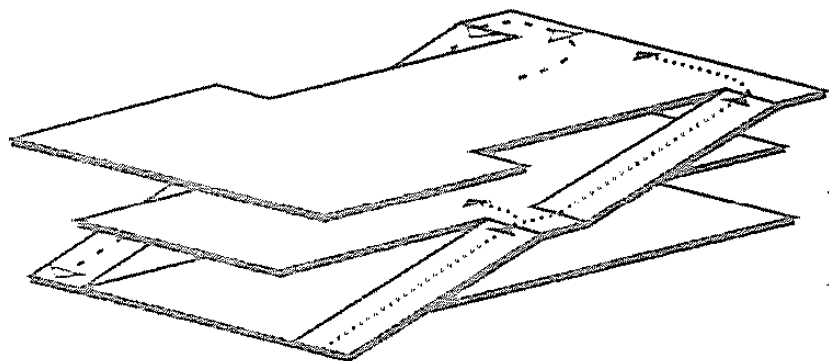

Jednosmjerne ravne rampe
max s = 15% pokrивene
max s = 12% otvorene

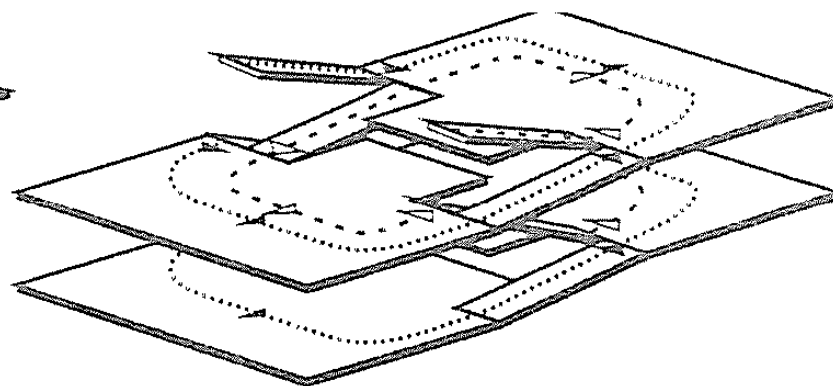

Dvosmjerne ravne rampe
max s = 15% pokrивene
max s = 12% otvorene

PROMET U MIROVANJU

ELEMENTI PROJEKTIRANJA GARAŽA

PRIMJERI PROSTORNIH RJEŠENJA

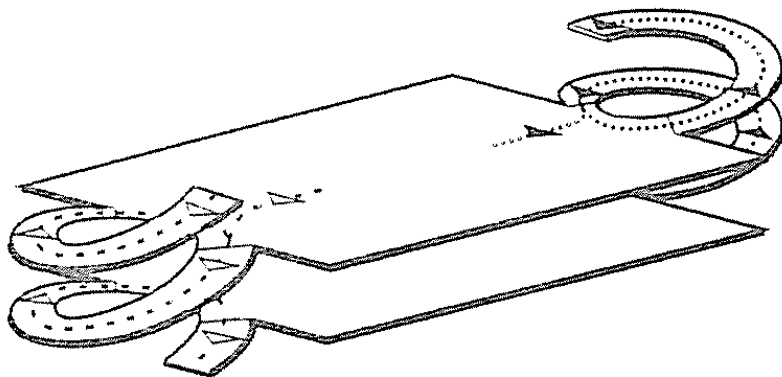

Jednosmjerne spiralne rampe
max $s = 12\%$

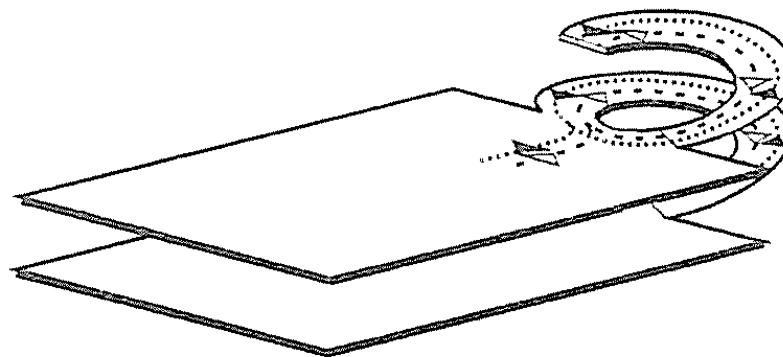

Dvosmjerne spiralne rampe
max $s = 12\%$

PROMET U MIROVANJU

ELEMENTI PROJEKTIRANJA GARAŽA

PRIMJERI PROSTORNIH RJEŠENJA

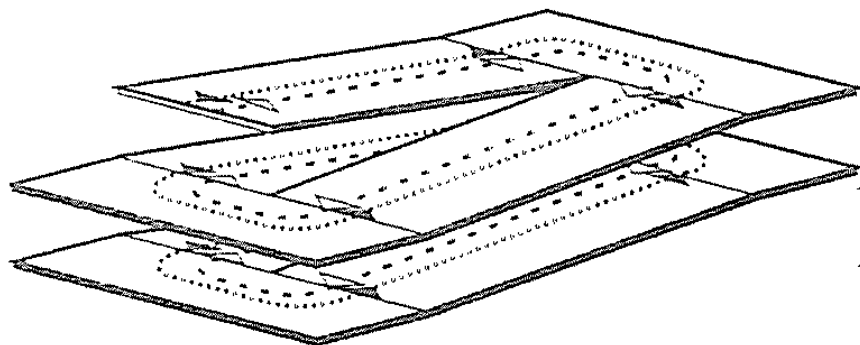

Dvosmjerne rampe sa jednokatnim
krakom
max $s = 5\%$

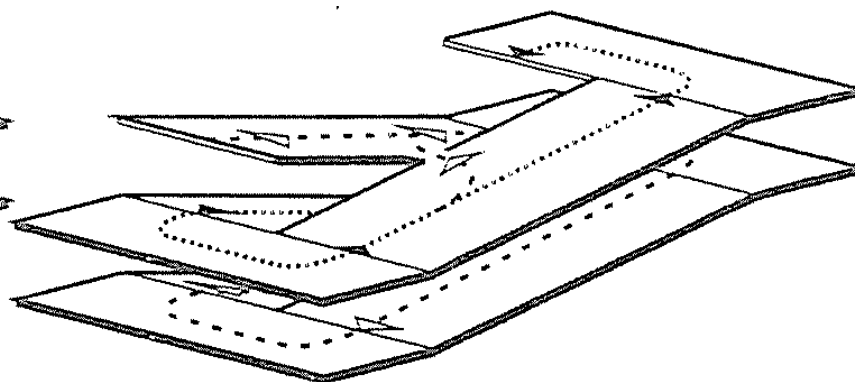

Jednosmjerne rampe sa dvokatnim
krakom
max $s = 5\%$

PROMET U MIROVANJU

ELEMENTI PROJEKTIRANJA GARAŽA

TLOCRTNO OBLIKOVANJE RAMPI KOD VIŠEETAŽNIH GARAŽA

RAVNE RAMPE

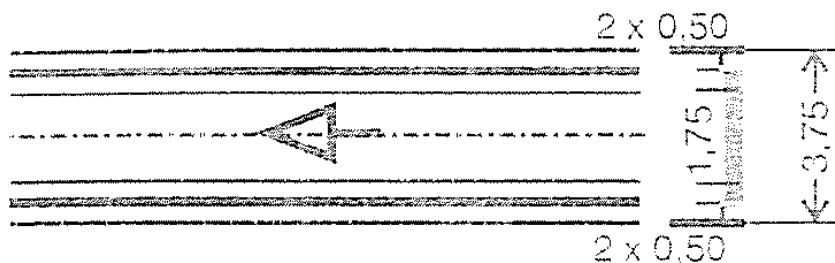

jednotračne

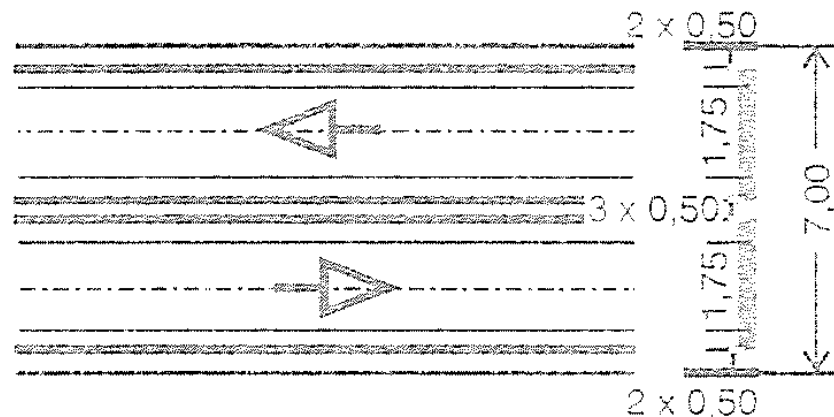

dvotračne

PROMET U MIROVANJU

ELEMENTI PROJEKTIRANJA GARAŽA

TLOCRTNO OBLIKOVANJE RAMPI KOD VIŠEETAŽNIH GARAŽA

KRUŽNE RAMPE

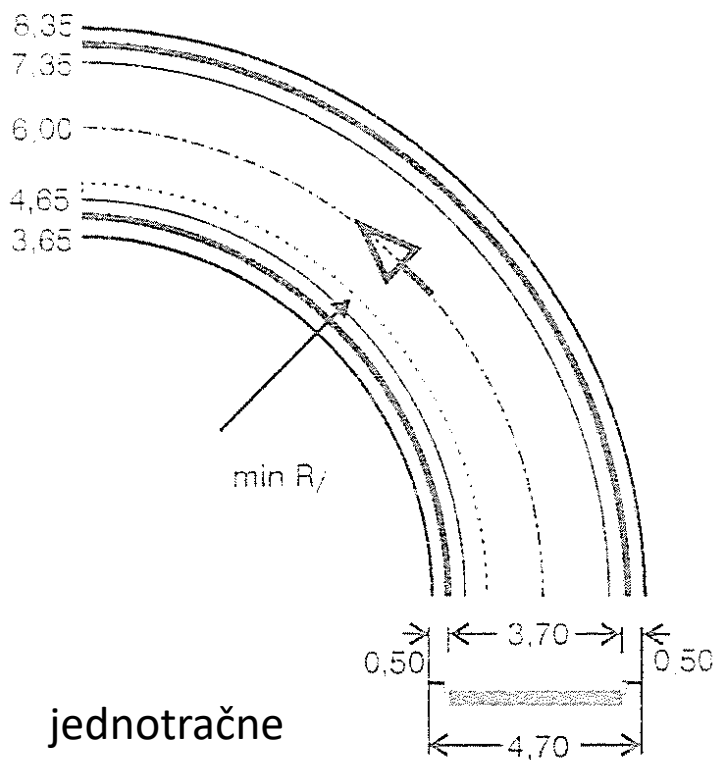

jednotračne

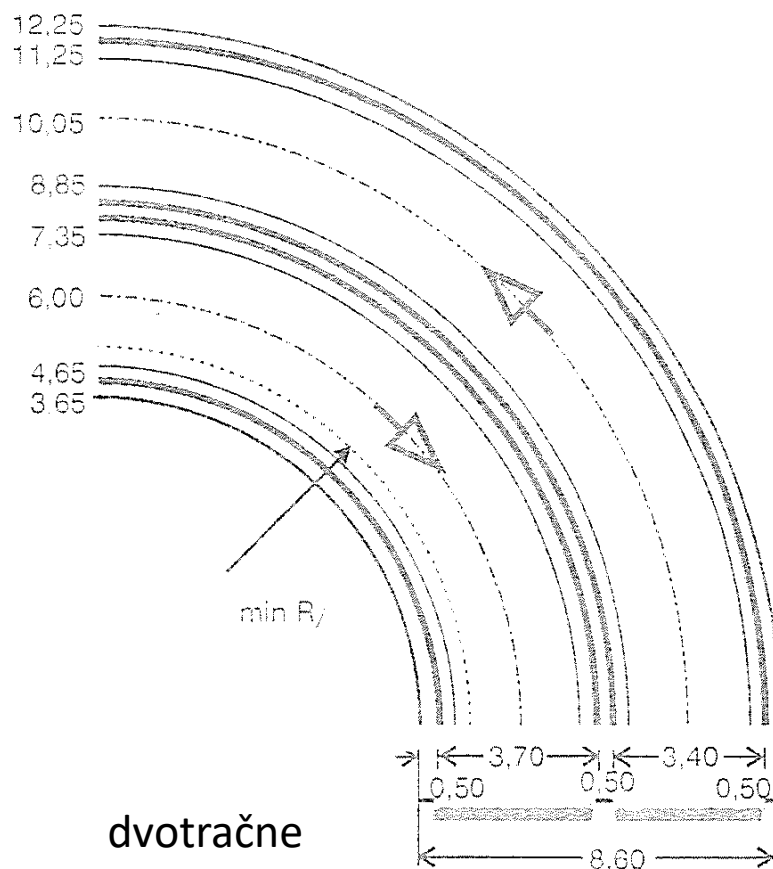

dvotračne

PROMET U MIROVANJU

ELEMENTI PROJEKTIRANJA GARAŽA

TLOCRTNO OBLIKOVANJE RAMPI KOD VIŠEETAŽNIH GARAŽA

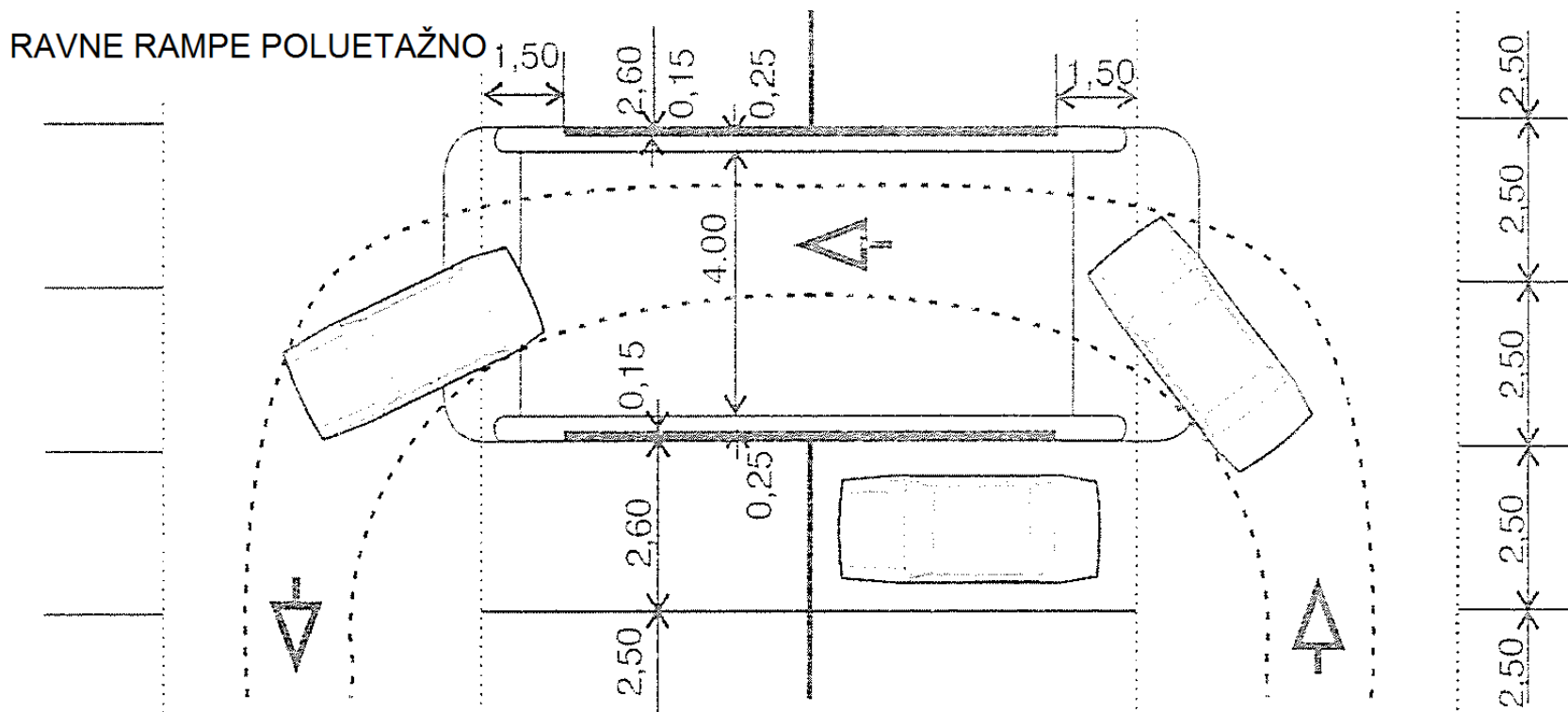

PROMET U MIROVANJU

RAMPE KOD VIŠEETAŽNIH GARAŽA



PROMET U MIROVANJU

RAMPE KOD VIŠEETAŽNIH GARAŽA



PROMET U MIROVANJU

RAMPE KOD VIŠEETAŽNIH GARAŽA



PROMET U MIROVANJU

RAMPE KOD VIŠEETAŽNIH GARAŽA



PROMET U MIROVANJU

RAMPE KOD VIŠEETAŽNIH GARAŽA

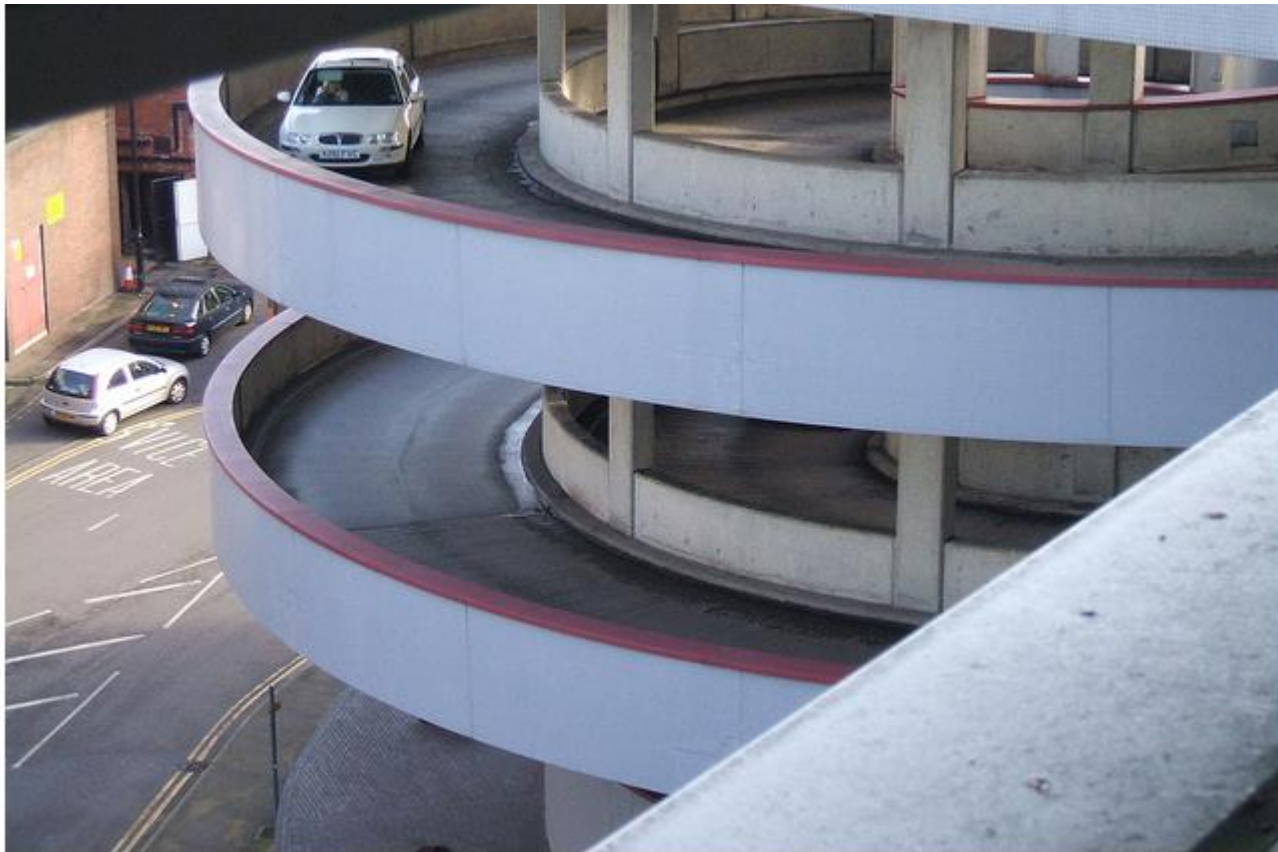

PROMET U MIROVANJU

ELEMENTI PROJEKTIRANJA GARAŽA

VISINSKO OBLIKOVANJE RAMPI KOD VIŠEETAŽNIH GARAŽA

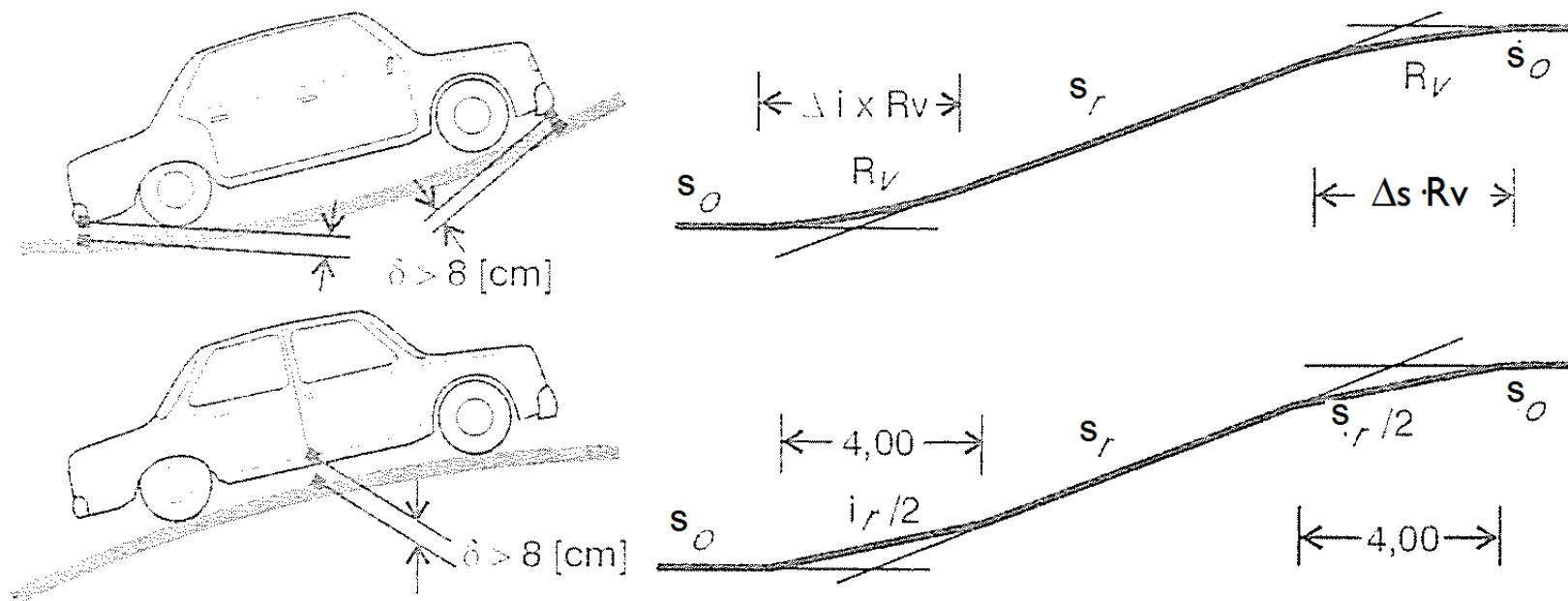

Oblikovanje prijeloma nivelete

PROMET U MIROVANJU

ELEMENTI PROJEKTIRANJA GARAŽA

MEHANIČKE GARAŽE

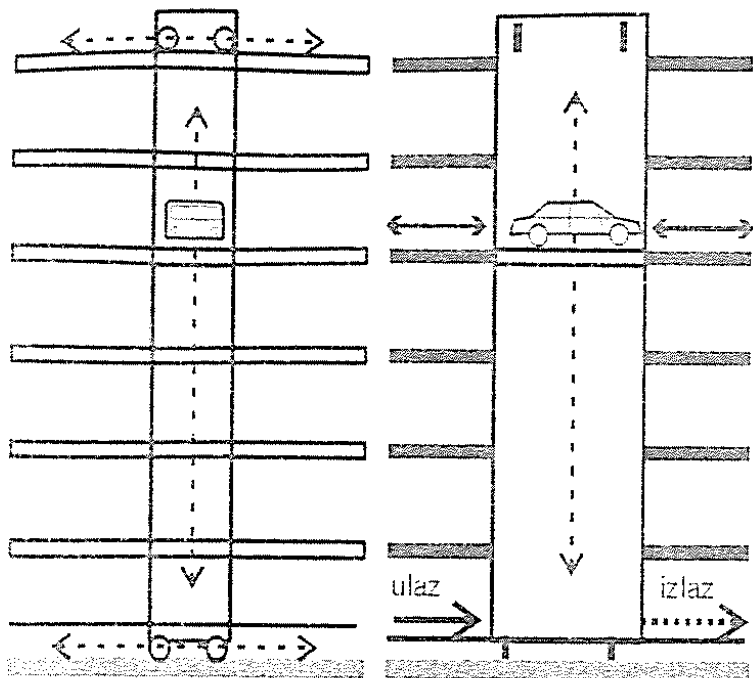

Garaže tipa tornja

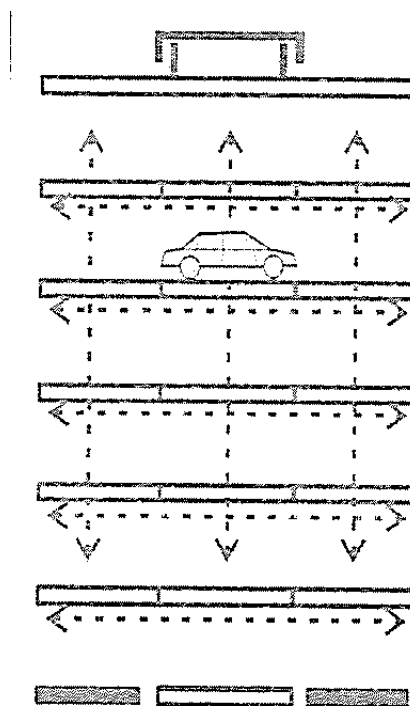

Garaže paletnog tipa

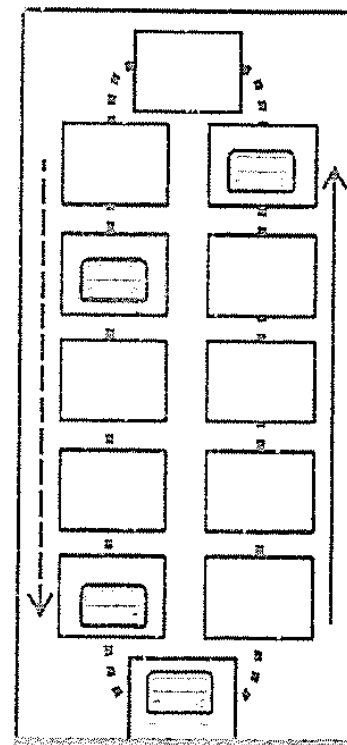

Garaže sa vezanim kabinama

PROMET U MIROVANJU

MEHANIČKE GARAŽE



PROMET U MIROVANJU

MEHANIČKE GARAŽE

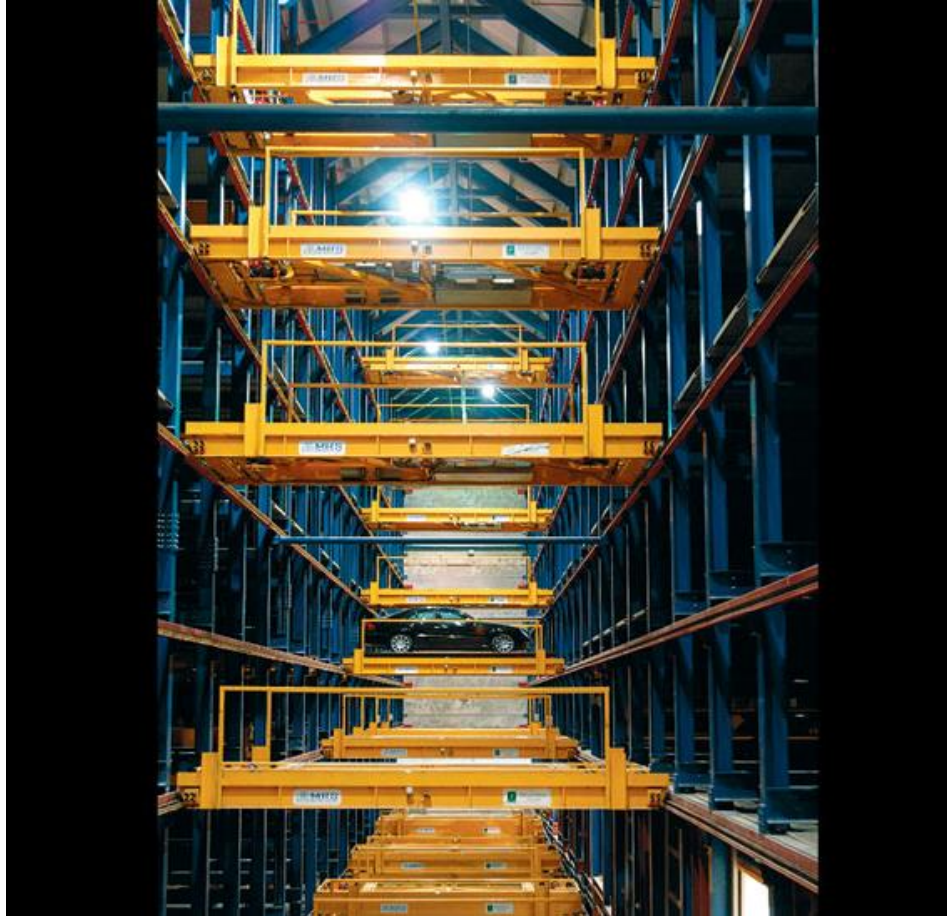

PROMET U MIROVANJU

MEHANIČKE GARAŽE

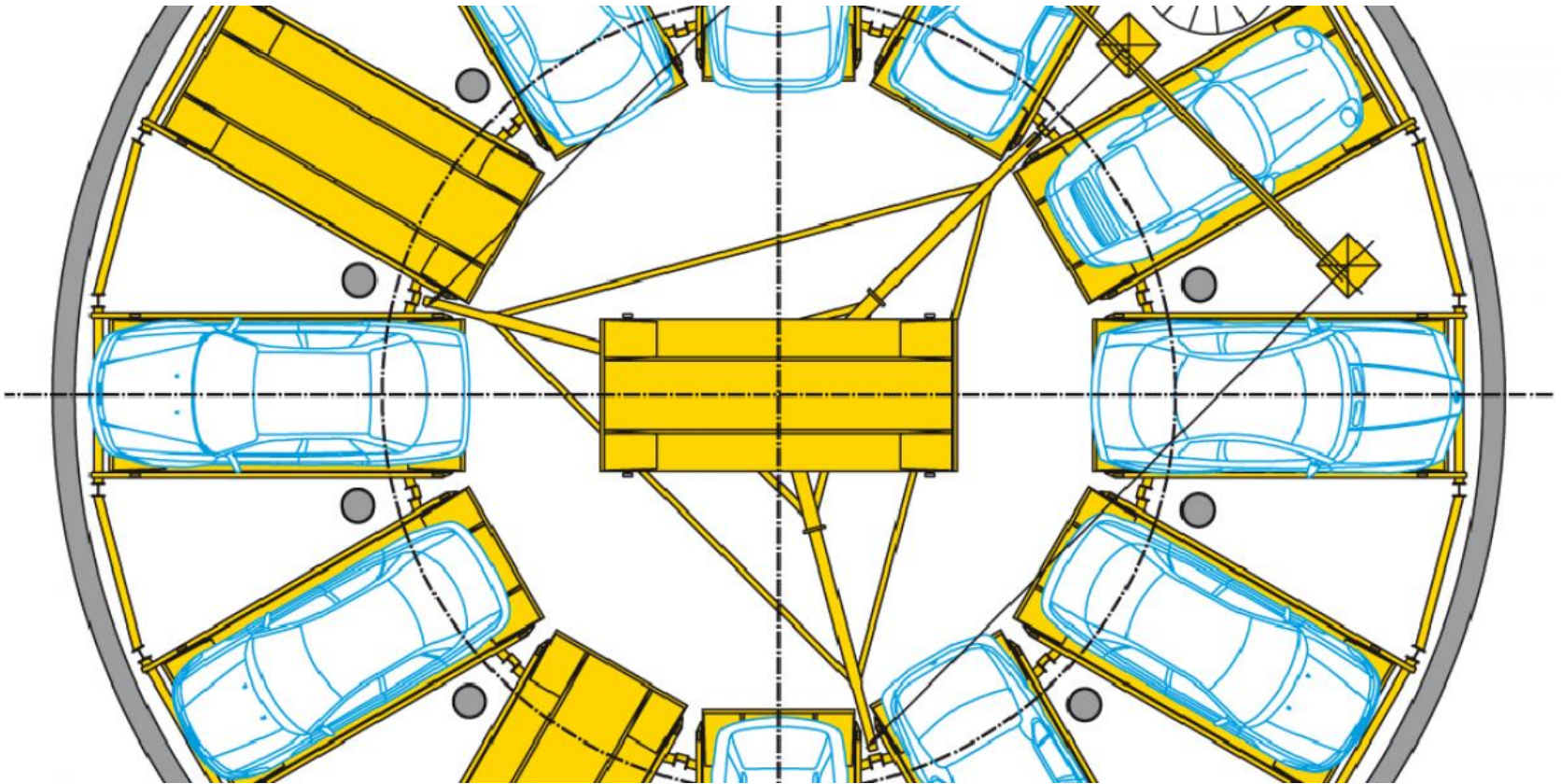

PROMET U MIROVANJU

MEHANIČKE GARAŽE

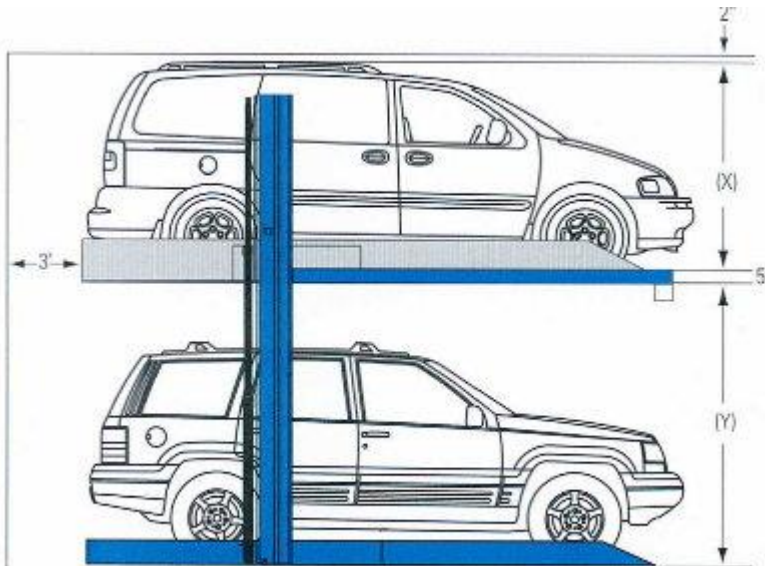

PROMET U MIROVANJU

MEHANIČKE GARAŽE

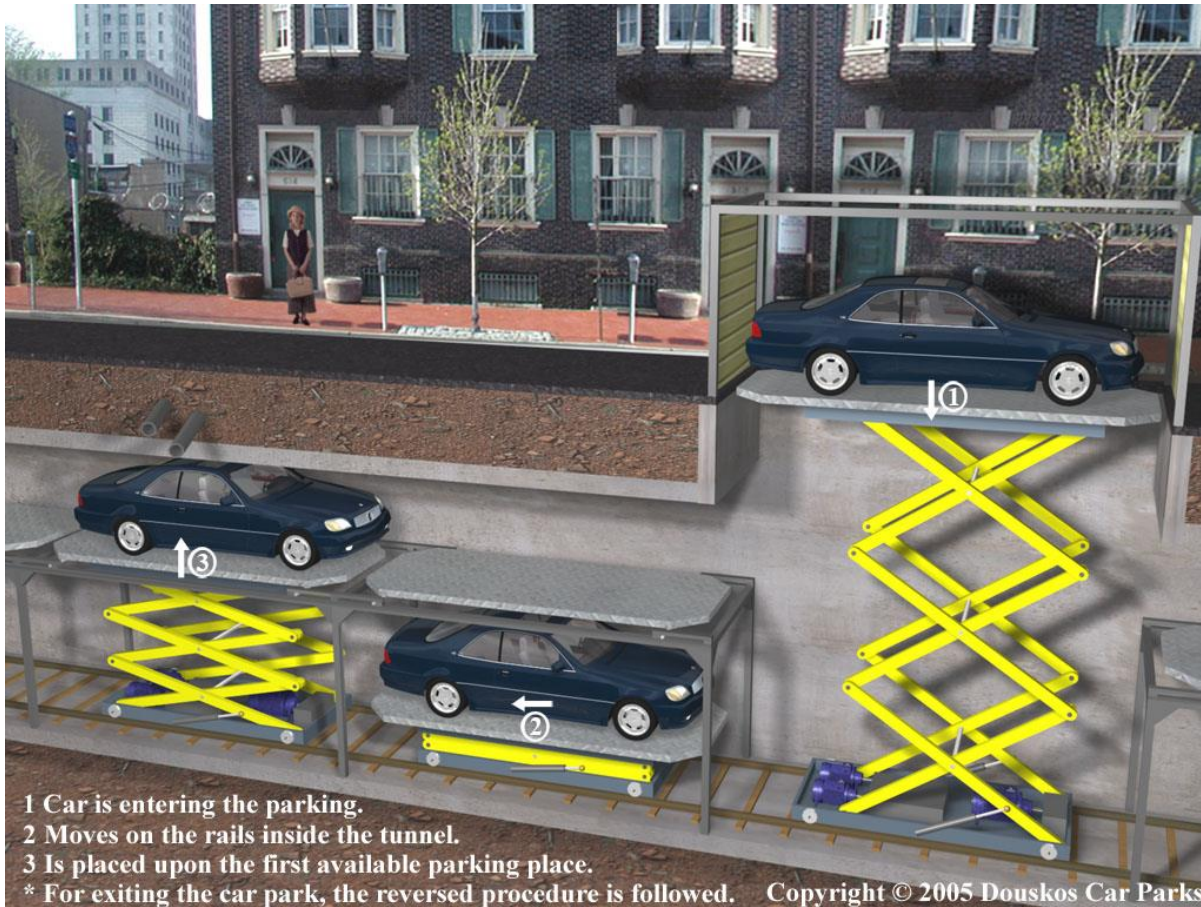

PROMET U MIROVANJU

TIPSKA RJEŠENJA PARKIRALIŠTA ZA TERETNA VOZILA

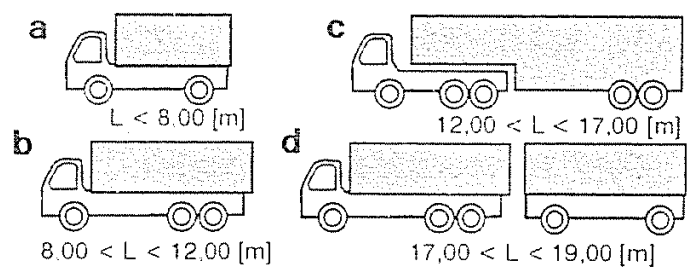
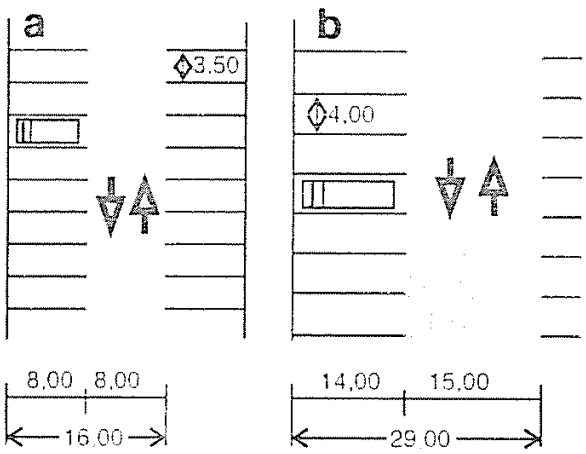
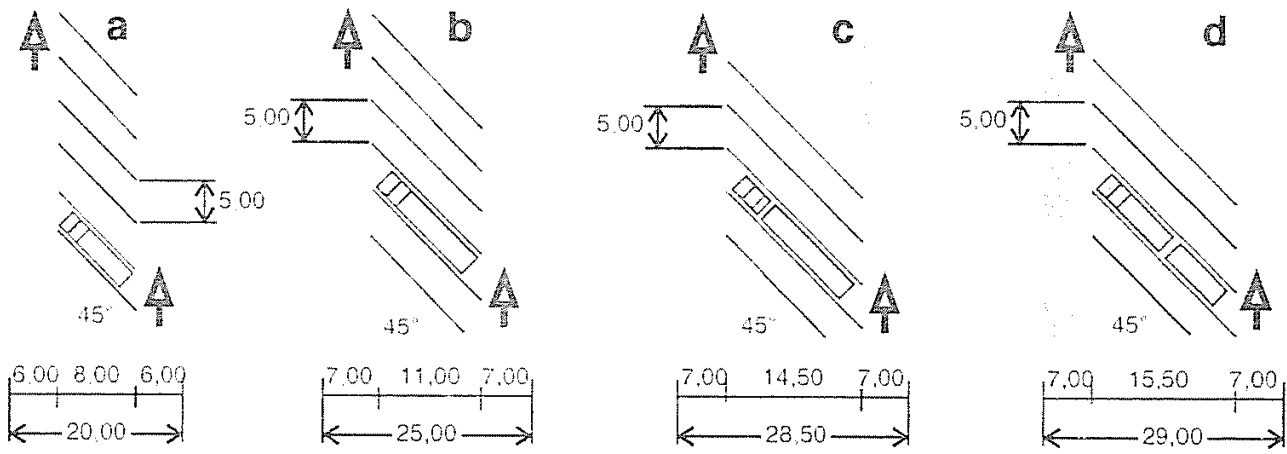

Različita mjerodavna teretna vozila

PROMET U MIROVANJU

PARKIRALIŠTA ZA TERETNA VOZILA



PROMET U MIROVANJU

PARKIRALIŠTA ZA AUTOBUSE



www.shutterstock.com · 3061023



PROMET U MIROVANJU

TIPSKA RJEŠENJA PARKIRALIŠTA ZA BICIKLE

U gradovima, posebno u blizini javnih, poslovnih, industrijskih zgrada potrebno je osigurati parkirališta za bicikle koja će biti opremljena držačima za sigurno odlaganje bicikala. Držači mogu biti za naslanjanje bicikala ili za prednje kotače za okomito, koso ili vodoravno postavljanje bicikala.

Boksovi za bicikle ili biciklističke garaže su najsigurniji objekti za čuvanje bicikala.



PROMET U MIROVANJU

TIPSKA RJEŠENJA PARKIRALIŠTA ZA BICIKLE

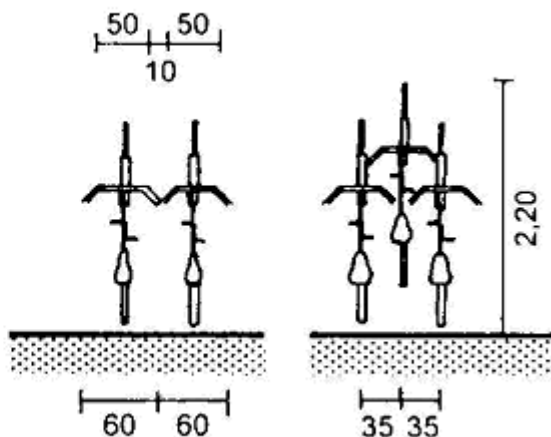
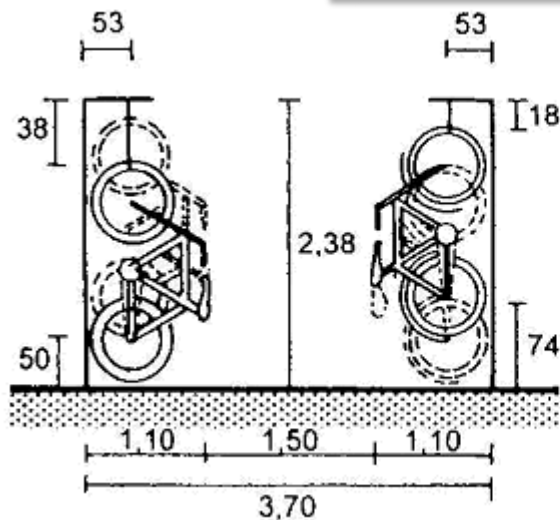

Okomiti položaj

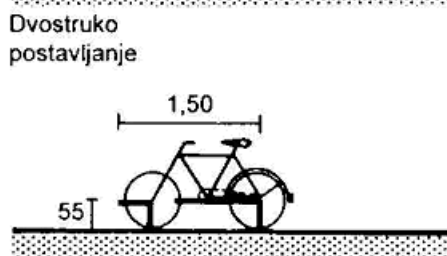
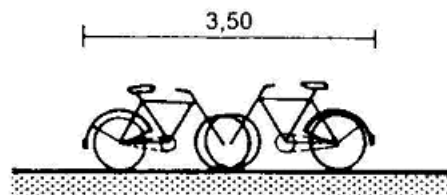
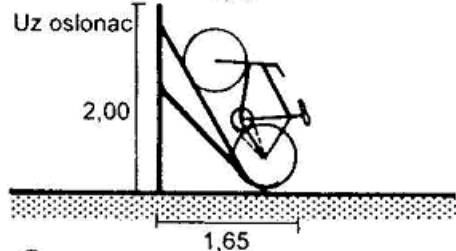
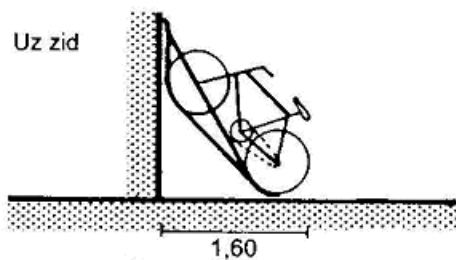

Kosi i vodoravni položaj

PROMET U MIROVANJU

TIPSKA RJEŠENJA PARKIRALIŠTA ZA BICIKLE

RUBNO PARKIRANJE

širina 0,60 (m)

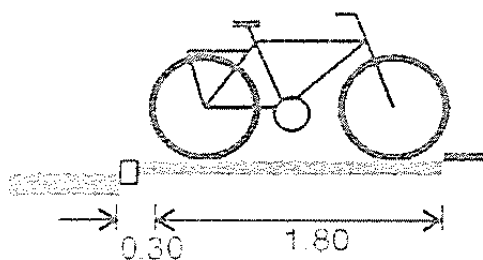

SAMOSTALNO PARKIRANJE (pokriveno)

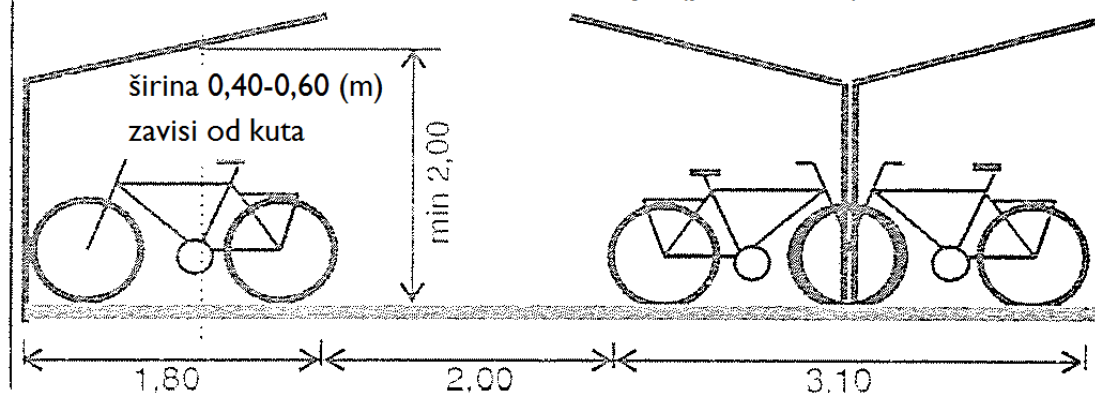

SAMOSTALNO PARKIRANJE

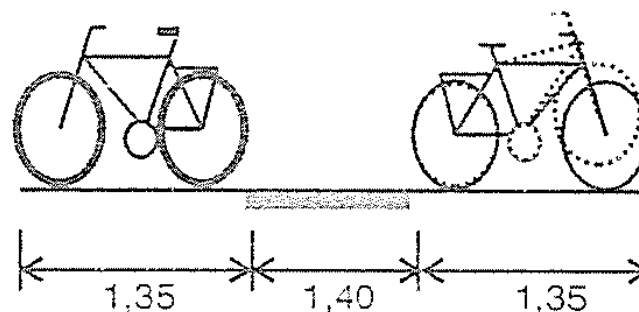
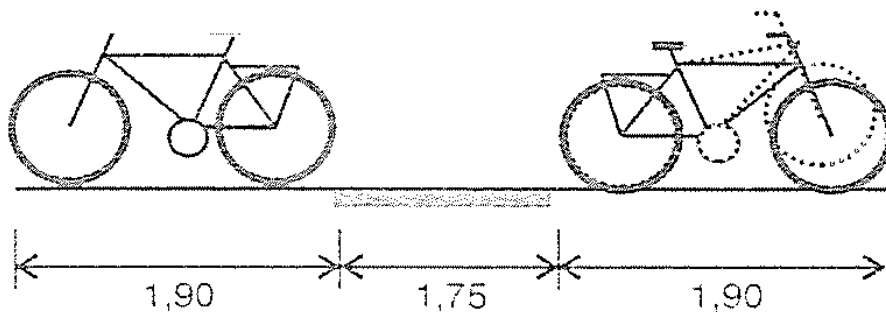

PROMET U MIROVANJU

TIPSKA RJEŠENJA PARKIRALIŠTA ZA BICIKLE

PARKING MODULI

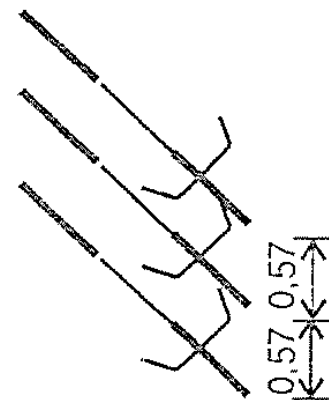
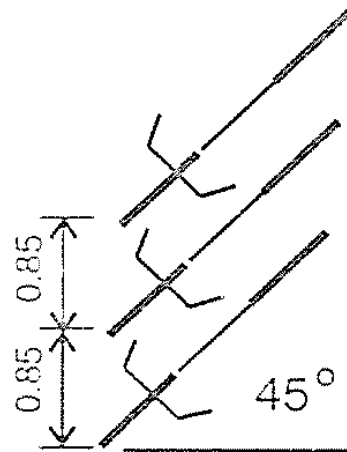
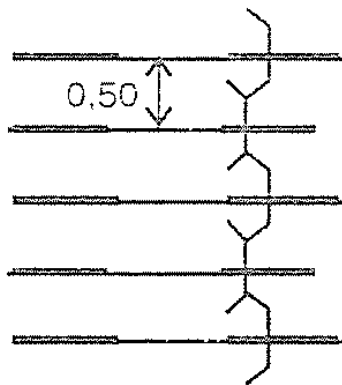
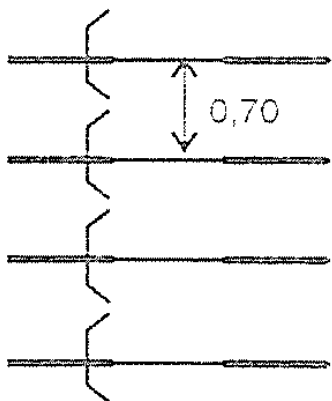

PROMET U MIROVANJU

TIPSKA RJEŠENJA PARKIRALIŠTA ZA BICIKLE

RAZLIČITA RJEŠENJA NADSTREŠNICA NAD PARKIRALIŠTIMA ZA BICIKLE

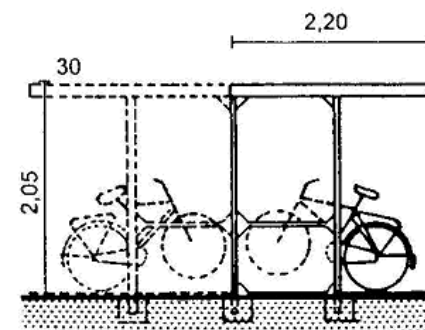
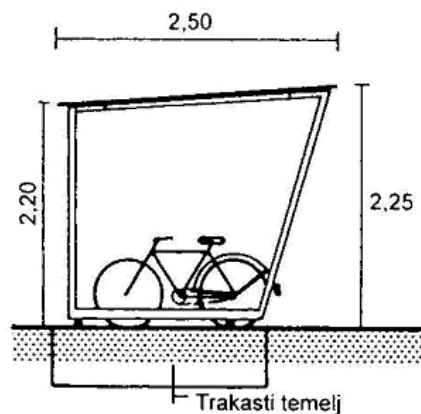
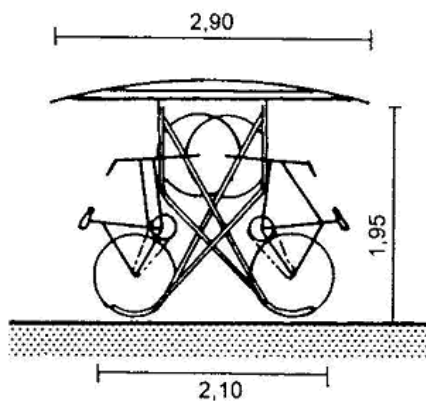
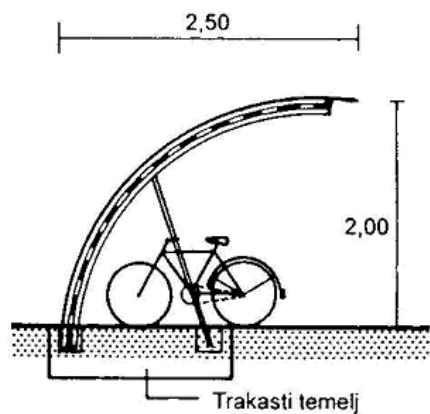

PROMET U MIROVANJU

PARKIRALIŠTA ZA BICIKLE



Nunspeet, Netherlands

PROMET U MIROVANJU

PARKIRALIŠTA ZA BIKIKLE



Amsterdam

PROMET U MIROVANJU

PARKIRALIŠTA ZA BICIKLE





HVALA NA PAŽNJI